



**STUNNING  
COLORS**

**COULEURS SUPERBES  
BEEINDRUCKENDE FARBEN**

**Celestial**  
**SPOTLIGHT SYSTEM**  
SYSTÈME D'ÉCLAIRAGE SPOT | SPOTLIGHT-SYSTEM

**Owner's Manual**  
**Manuali dei Prodotti**  
使用説明書

**Bedienungsanleitung**  
**Manual do Proprietário**  
Instrukcje obsługi

**Mode d'emploi**  
用戶手冊



***Dear Customer,***

Thank you for purchasing this product.

For optimum performance and safety, please read these instructions carefully.

English

**User Memo:**

Date of purchase: \_\_\_\_\_

Dealer name: \_\_\_\_\_

Dealer address: \_\_\_\_\_

Dealer website: \_\_\_\_\_

Dealer email: \_\_\_\_\_

Dealer phone no.: \_\_\_\_\_

**Please visit us on facebook or twitter!**



<https://www.facebook.com/Maxspect>



<http://twitter.com/maxspectled>

## Package Content

Please check the content in the package.

English

**Celestial LED Module**



**Power Supply Unit**



**Stand**



Before using this Maxspect™ Celestial LED Lighting System please read these operating instructions carefully. Take special care to follow the safety suggestions listed below.

Afterwards keep this manual handy for future reference.

## Before using the Maxspect™ Celestial LED Lighting System

1. Remove any plastic bags and packaging material protecting the fixture.
2. Never look directly at the LED bulbs when you switch on the system. Incorrect use of this apparatus will increase eye hazard.

## On Safety

1. **Power Source** – Do not defeat the safety purpose of the polarized or grounding-type plug. A polarized plug has two blades with one wider than the other. A grounding-type plug has two blades and a third grounding prong. The wide blade or the third prong are provided for your safety. If the plug does not fit into your outlet, consult an electrician for replacement of the obsolete outlet.
2. **Power Cord Protection** – The power supply cords should be routed so that they are not likely to be walked on or pinched by items placed upon or against them. Never take hold of the plug or cord if your hand is wet, and always grasp the plug body when connecting or disconnecting it.
3. **Installation** – Install indoor only, and use the attachments, mounting frames, hanging kit and accessories provided and specified by the manufacturer.

## On Operation

1. **Operation** – Always follow the operation instructions set forth in this manual when using this Celestial LED Lighting System.
2. **Heat** – The apparatus should be situated away from heat sources such as radiators, and do not expose to excessive heat such as sunshine, fire or the like.
3. **Moisture** – To reduce the risk of fire or electric shock, do not expose this apparatus to rain, moisture, dripping or splashing.
4. **Ventilation** – The apparatus should be situated so that its location or position does not interfere with its proper ventilation.
5. **Magnetism** – The apparatus should be situated away from equipment or devices that generate strong magnetism.
6. **Cleaning** – Clean only with dry cloth.

## Mounting the Celestial LED Lighting System

Before connecting the LED Modules to Power Supply, first mount the system by using the provided Stand.

### 1. Assemble the Stand.

Assemble the stand by inserting the rails into side of the Celestial LED Module, as illustrated in the following diagram.



### 2. Tighten the Thumb Screws.

Tighten the thumb screws to secure the position of the stand.

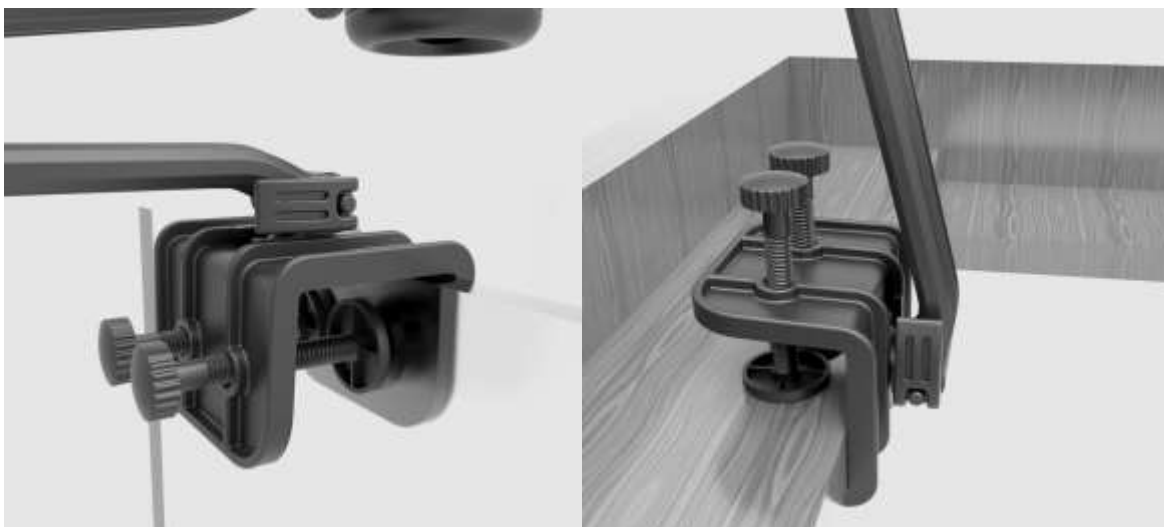

### 3. Adjust the angle.



# Operating Instructions

English

## Basic Operations

Follow the instructions below to operate and program the Celestial LED Module.

### Note

**The LED Module turns on automatically when power is connected, and turns off when power is cut.**

When power is resumed, the LED Module will restore to the previous saved setting automatically, whether it was last set at Manual, Preset or Automatic Mode, and the intensity level of all the LED channels.

**The Maxspect logo will be displayed with the firmware version when power is connected.**

MAXSPECT<sub>c1.1</sub>

## Switching between Manual and Automatic Mode



1. Press and hold the control dial for 2 seconds to switch between the 2 modes. The LCD panel will display "M" and "A" accordingly.

### Manual Mode:

<b>M</b>	A: 100%	B: 100%
	C: 100%	D: 100%

### Automatic Mode:

<b>A</b>	12: 30
A: 100%	B: 100%



## Manual Mode "M"

Under Manual mode, user can adjust the brightness of the two channels by using the control dial.



1. Press the control dial once to enter setup. Channel A will be selected by default. Rotate the dial to adjust its brightness.

<b>M</b>	A: <b>100%</b>	B: 100%
	C: 100%	D: 100%



2. Press the control dial again to switch to Channel B. Rotate the dial to adjust its brightness. Repeat the same for the other channels.

<b>M</b>	A: 60%	B: <b>100%</b>
	C: 100%	D: 100%

3. Press the control dial one more time to exit.
4. Note that C35-F/C70-F models have 4 channels, while C35-S/C35-A models only have 2 channels, the interface would look slightly different as illustrated below.

<b>M</b>	A: 100%
	B: 100%

## Automatic Mode "A"

Under the Automatic mode, users can program their own photo-period profile using the **On Time**, **Off Time** and **Maximum Brightness** settings of each channel.

The Channel will turn itself on at the **On Time**, starting from 0% brightness and slowly over a period of 30 minutes increases and reaches the **Maximum Brightness** set for that channel. Then it'll start to decrease brightness starting at the **Off Time**, over a period of 30 minutes then turn itself off.

For example, the following table demonstrates how you could program the channels such that Channel A would light up from 8:00am, reaches 80% brightness at 8:30am and remain there until 4:30pm, then decrease until turning off at 5:00pm. Similarly, Channel B would light up from 8:30am, reaches 60% brightness at 9:00am and remain there until 11:00pm, then decrease until turning off at 11:30pm.

	Maximum Brightness	On Time	Off Time
Channel A	80%	08:00	16:30
Channel B	65%	08:30	23:00

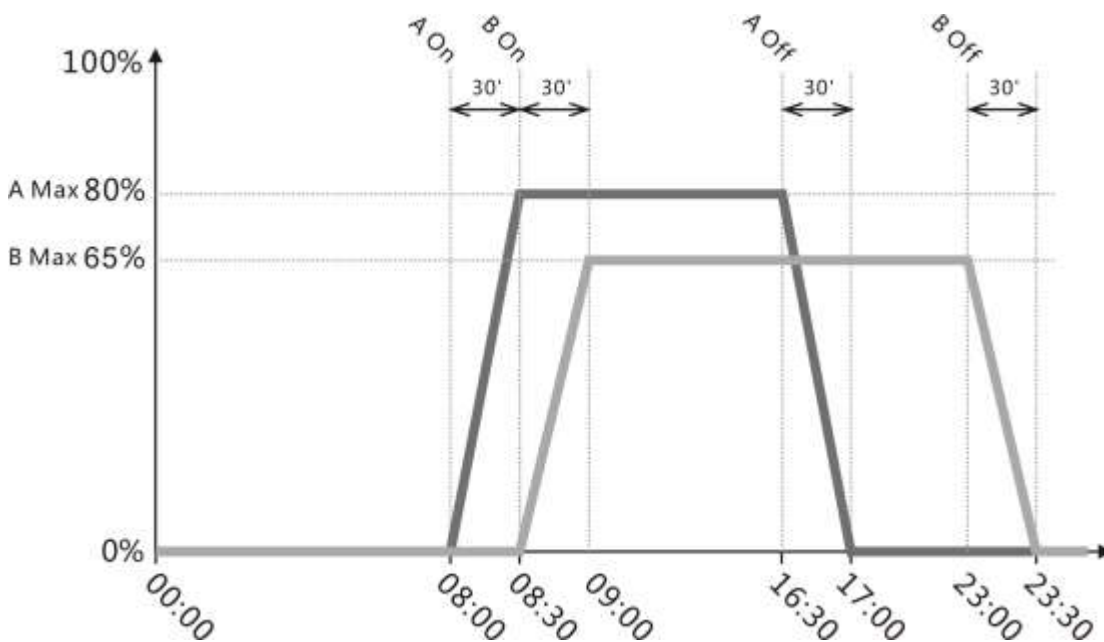

## Automatic mode – Setting the clock



1. Press the control dial once to enter setup.

A **TIME**  
S PROGRAM



2. Once you are in the clock setting mode, the hour digit is selected by default. Rotate the dial to set the hour. (e.g. 06:30 → 08:30)

A TIME:  
S **08**: 30



3. Press the control dial to change to the minute digit. Rotate the dial to set the minute.

A TIME:  
S 08: **30**

4. When finished, press and hold the control dial for 2 seconds to exit setup.

# Operating Instructions

English

## Automatic mode – Programming the Photo-Period



1. Press the control dial once to enter setup.

A	<b>TIME</b>
S	PROGRAM



2. Rotate the dial to select between which setting you wish to change. (e.g. Time → Program)

A	TIME
S	<b>PROGRAM</b>



3. Press the control dial again to select the setting, the first channel (A) is selected. Rotate the dial to change the channel. (e.g. A → B)

A	<b>A</b>	Max: 100%
S		On: 00:00

## Operating Instructions

English



4. Press the control dial to change to the brightness setting. Rotate the dial to adjust the brightness. (e.g. 100% → 80%)

A	<b>B</b>	Max: 100%
<b>S</b>		On: 00:00



5. Press the control dial to change to the **On Time** setting. Rotate the dial to adjust the **On Time**, the time increments every 30 minutes. (e.g. 00:00 → 08:30)

A	<b>B</b>	Max: 80%
<b>S</b>		On: 00:00



6. Press the control dial again to change to the **Off Time** setting. Rotate the dial to adjust the **Off Time**, the time increments every 30 minutes. (e.g. 00:00 → 22:30)

A	<b>B</b>	Max: 80%
<b>S</b>		Off: 00:00

7. When finished, press and hold the control dial for 2 seconds to exit setup.



## Limited Warranty

English

Maxspect Ltd. warrants all Maxspect™ Celestial LED Lighting System products against defects in workmanship for a period of 12-months from the date of purchase. If a defect exists during the warranty period, Maxspect Ltd. at its option will either repair (using new or remanufactured parts) or replace (with a new or remanufactured unit) the product at no charge.

THE WARRANTY WILL NOT APPLY TO THE PRODUCT IF IT HAS BEEN DAMAGED BY MISUSE, ALTERATION, ACCIDENT, IMPROPER HANDLING OR OPERATION, OR IF UNAUTHORIZED REPAIRS ARE ATTEMPTED OR MADE. SOME EXAMPLES OF DAMAGES NOT COVERED BY WARRANTY INCLUDE, BUT ARE NOT LIMITED TO, USING AFTER-MARKET LED BULBS AND MODIFICATION OF THE CIRCUITRY, WHICH ARE PRESUMED TO BE DAMAGES RESULTING FROM MISUSE OR ABUSE.

### **DISCLAIMER OF CONSEQUENTIAL AND INCIDENTAL DAMAGES:**

You and any other user of Maxspect Ltd. products shall not be entitled to any consequential or incidental damages, including without limitation, loss of use of the unit, inconvenience, damage to personal property, phone calls, lost income or earnings. This warranty gives you specific legal rights and you may also have other rights, which vary from state to state.

MAXSPECT LTD. MAKES NO WARRANTY OR REPRESENTATION, EITHER EXPRESS OR IMPLIED, WITH RESPECT TO THE PRODUCT'S QUALITY, PERFORMANCE, MERCHANTABILITY, OR FITNESS FOR A PARTICULAR PURPOSE. AS A RESULT, THIS PRODUCT, IS SOLD "AS IS," AND YOU THE PURCHASER ASSUME THE ENTIRE RISK AS TO ITS QUALITY AND PERFORMANCE.

IN NO EVENT WILL MAXSPECT LTD BE LIABLE FOR DIRECT, INDIRECT, SPECIAL, INCIDENTAL, OR CONSEQUENTIAL DAMAGES RESULTING FROM ANY DEFECT IN THE PRODUCT OR ITS DOCUMENTATION.

The warranty, disclaimer, and remedies set forth above are exclusive and replace all others, oral or written, expressed or implied. At no time will any Maxspect Ltd. dealers, agents, or employees be authorized to make any modifications, extension, or addition to this warranty.

Some states do not allow the exclusion or limitation of implied warranties or liability for incidental or consequential damages, so the above limitation or exclusion may not apply to you.

# Specifications

English

<b>LED Module</b>	<b>Dimensions (L x W x H)</b>	
	<b>Celestial</b>	140mm × 85mm x 65mm (5.5" x 3.3" x 2.5")
	<b>C35-F, C35-S, C35-A</b>	
	<b>Celestial</b>	150mm × 100mm x 85mm (6" x 4" x 3.3")
	<b>C70-F</b>	
	<b>Weight</b>	
	<b>Celestial</b>	250g (0.6 lb)
	<b>C35-F, C35-S, C35-A</b>	
	<b>Celestial</b>	400g (0.9 lb)
	<b>C70-F</b>	

---

<b>Power Supply Unit</b>	<b>Model</b>	GM50-240200-F (C35) GM601-240300 (C70)
	<b>Input Voltage / Current</b>	1.5A/100-240vAC 50/60Hz
	<b>Output Voltage / Current</b>	24vDC 2A (C35) 24vDC 3A (C70)
	<b>Weight</b>	250g /0.6 lb (C35) 250g /0.8 lb (C70)

**Note:**

For latest specifications on LED layout, types and color spectrum, please visit our website at [www.maxspect.com](http://www.maxspect.com)

Specifications are subject to change without notice.

Weight and dimensions are approximate.



## ***Sehr geehrter Kunde,***

vielen Dank für den Kauf dieses Produkts.

Für eine optimale Leistung und Sicherheit, lesen Sie bitte diese Anleitung sorgfältig.

### **Nutzer-Memo:**

Kaufdatum	_____
Händler:	_____
Händleradresse:	_____ _____
Händlerwebsite:	_____
Händler-E-Mail:	_____
Händlertelefon	_____

Deutsch

### **Bitte besuchen Sie uns auf Facebook oder Twitter!**



<https://www.facebook.com/Maxspect>



<http://twitter.com/maxspectled>

## Packungsinhalt

Bitte überprüfen Sie den Lieferumfang auf Vollständigkeit.

Celestial LED Modul



Netzteil



Aufsetzsystem



Deutsch

Vor der ersten Inbetriebnahme des Maxspect™ LED-Beleuchtungssystems Celestial sollten Sie diese Bedienungsanleitung sorgfältig lesen. Bitte beachten Sie die folgenden Sicherheitshinweise mit großer Sorgfalt. Bewahren Sie diese Anleitung auch zum späteren Nachschlagen auf.

### Vor der Benutzung des Maxspect™ Celestial LED-Beleuchtungssystems

1. Falls vorhanden, entfernen Sie vor der Benutzung alle Schutzfolien.
2. Schauen Sie nie direkt in die LED-Leuchten wenn Sie das System einschalten. Die unsachgemäße Nutzung dieses Geräts kann eine Gefahr für die Augen bedeuten.

### Zur Sicherheit

1. **Stromquelle** – Setzen Sie die sicherheitsrelevanten Merkmale eines gepolten oder eines geerdeten Steckers nicht außer Kraft. Ein geerdeter Stecker verfügt über zwei Stifte und über einen dritten Erdungsstift. Der Erdungsstift ist zu Ihrer Sicherheit vorhanden. Sollte der Stecker nicht in Ihre Steckdose passen, kontaktieren Sie einen Elektriker, um die veraltete Dose austauschen zu lassen.
2. **Netzkabel** – Die Netzkabel sollten so verlegt werden, dass man nicht darüber steigen muss und sie auch nicht von Gegenständen beschädigt werden können, die unter oder neben den Kabeln liegen. Fassen Sie den Stecker oder das Kabel nie mit nassen Händen an und greifen Sie den Stecker beim Einstecken oder Abziehen immer direkt an.
3. **Installation** – Nur im Innenbereich benutzen und verwenden Sie nur die vom Hersteller mitgelieferten Zubehörteile, Befestigungsrahmen und Aufhängensysteme.

### Zum Betrieb

1. **Bedienung** – Befolgen Sie immer die Bedienhinweise dieses Handbuchs, wenn Sie das Celestial LED-Beleuchtungssystem nutzen.
2. **Hitze** – Das Gerät sollte fern von Wärmequellen, wie zum Beispiel Heizkörpern, aufgestellt werden und darf keiner großen Hitze, wie etwa Sonneneinstrahlung oder Feuer, ausgesetzt werden.
3. **Feuchtigkeit** – Zur Verringerung der Stromschlaggefahr darf das Gerät nicht mit Regen, Feuchtigkeit, Tropf- und Spritzwasser in Kontakt kommen.
4. **Belüftung** – Das Gerät sollte so aufgestellt werden, dass Standort und Position die Belüftung des Geräts nicht beeinträchtigen.
5. **Magnetismus** – Das Gerät sollte fern von Anlagen oder Geräten aufgestellt werden, die starken Magnetismus erzeugen.
6. **Reinigung** – Reinigen Sie das Gerät nur mit einem trockenen Tuch.

## Montieren des Celestial LED-Beleuchtungssystems

Bevor Sie die LED-Module mit dem Steuergerät verbinden, montieren Sie zunächst das System mit Hilfe des Aufsetzsystems.

### 1. Montage des Aufsetzsystems

Montieren Sie das Celestial Befestigungssystem durch Einfügen der Schienen in den dafür vorgesehenen Bereich des LED-Moduls, wie in den folgenden Schaubildern dargestellt.



### 2. Festziehen der Handschrauben.

Die Schrauben festziehen um die Position des Aufsetzsystems zu sichern.

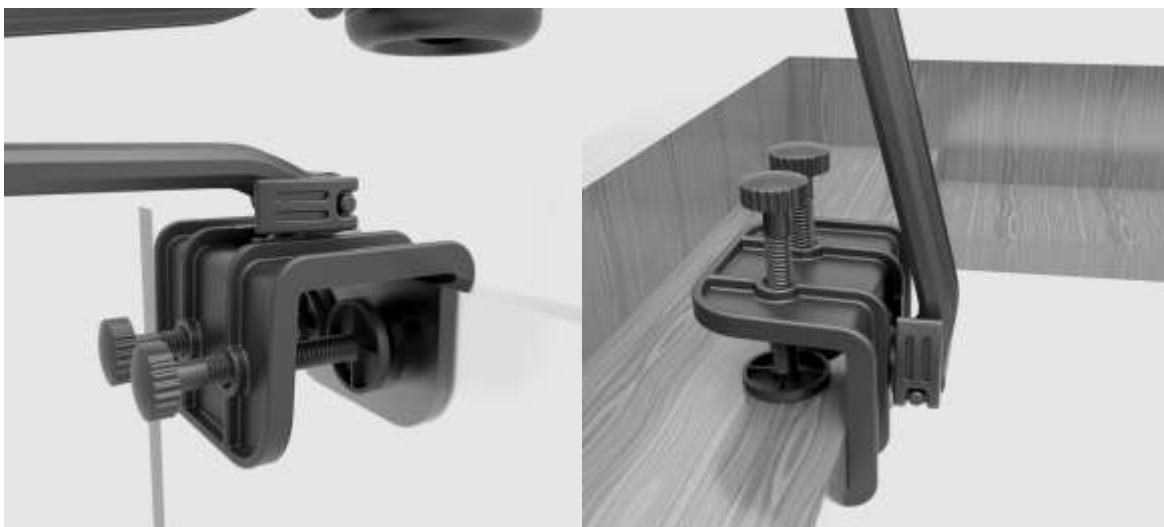

## 3. Einstellen des gewünschten Winkel.

Deutsch



## Benutzung

Befolgen Sie die nachstehenden Anweisungen um die Maxspect Celestial bedienen und Programmieren.

### Hinweis

**Sobald Die Celestial an das Stromnetz angeschlossen wird schaltet sie sich automatisch ein, und schaltet sich aus, wenn sie vom Stromnetz getrennt wird**

Wenn die Stromversorgung wieder eingeschaltet wird, kehrt die Celestial auf die früheren automatisch gespeicherten Einstellungen wieder zurück.

**Das Maxspect Logo wird mit der Firmware-Version angezeigt, wenn die Stromversorgung angeschlossen ist.**

MAXSPECT<sub>c1.1</sub>

## Wechseln zwischen Manuel und Automatikmodus



1. Drücken und halten Sie den Drehregler für 2 Sekunden um zwischen den 2 Modi zu wechseln. Das LCD-Display zeigt "M" und "A" entsprechend an.

### Manuel Modus:

<b>M</b>	A: 100%	B: 100%
	C: 100%	D: 100%

### Automatik Modus:

<b>A</b>	12: 30
A: 100%	B: 100%

## Manuel Modus "M"

Im manuellen Modus können Sie die Helligkeit der beiden Kanäle mithilfe des Drehreglers manuell anpassen.



1. Drücken Sie den Drehregler einmal um in das Setup-Menü zu gelangen. Kanal A wird standardmäßig ausgewählt. Drehen Sie den Drehregler um die Helligkeit anzupassen.

<b>M</b>	A: <b>100%</b>	B: 100%
	C: 100%	D: 100%



2. Drücken Sie den Drehregler einmal um den Kanal B auszuwählen. Drehen Sie den Drehregler um die Helligkeit anzupassen. Wiederholen Sie das gleiche für die anderen beide Kanäle.

<b>M</b>	A: 60%	B: <b>100%</b>
	C: 100%	D: 100%

3. Drücken Sie den Drehregler noch einmal um das Setup-Menü zu verlassen.
4. Beachten Sie, dass die C35-F/C70-F Modelle 4 Kanäle haben, während die C35-S/C35-A Modelle nur 2 Kanäle haben. Dadurch sieht das Display etwas anders aus, wie nachstehend dargestellt.

<b>M</b>	A: 100%
	B: 100%

## Automatik Modus "A"

In dem Automatik-Modus, können Sie Ihr eigenes Fotoperiodenprofil einstellen mit der Programmierung der "On Time" und "Off Time" sowie die "Maximum Brightness" der einzelnen Kanäle.

Deutsch

Der Kanal stellt sich auf "On Time" die Helligkeit startet bei 0% und nimmt langsam über einen Zeitraum von jeweils 30 Minuten zu bis "Maximum Brightness" für diesen Kanal erreicht ist. Dann beginnt "Off Time", mit dem verringern der Helligkeit ebenso über einen Zeitraum von jeweils 30 bis die Leuchte sich ausschaltet.

Zum Beispiel zeigt die folgende Tabelle, wie Kanal A programmiert wurde so dass ab 8h00 der Kanal A an geht und eine Helligkeit von 80% um 8h30 erreicht und dies bis 16h30. Ab dann wird die Helligkeit nachlassen bis Kanal A 0% um 17h00 erreicht hat. Ebenso würde Kanal B so programmiert das er ab 8h30 anfängt zu leuchten bis er um 9h00 60% Helligkeit erreicht hat und diese bis 23h00. Ab dieser Zeit wird die Helligkeit nachlassen bis Kanal B 0% um 23h30 erreicht hat.

	Maximum Brightness	On Time	Off Time
<b>Kanal A</b>	80%	08:00	16:30
<b>Kanal B</b>	65%	08:30	23:00

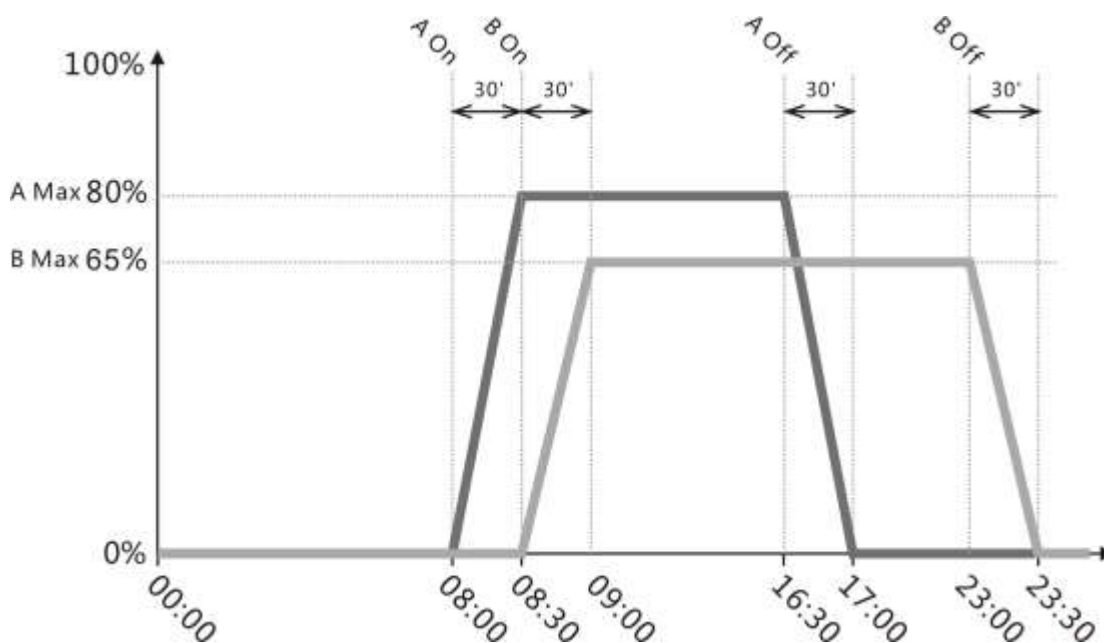



## Automatik Modus – Einstellen der Uhrzeit

1. In dem Zeiteinstellungsmodus sind die Stunden-Ziffern standardmäßig ausgewählt.

A TIME:  
S 06: 30



2. Drehen Sie den Drehregler um die Stunden einzustellen. (z.B. 06:30 auf 08:30)

A TIME:  
S 08: 30



3. Drücken Sie den Drehregler um zu den Minuten-Ziffern zu gelangen. Drehen Sie den Drehregler um die Minuten einzustellen. (z.B. 08:30 auf 08:45)

A TIME:  
S 08: 30

4. Wenn Sie fertig sind, drücken und halten Sie den Drehregler 2 Sekunden lang, um aus dem Setup Modus zu gelangen.

## Automatik Modus – Programmierung der Leuchtperiode

Deutsch



1. Drücken Sie den Drehregler einmal um in das Setup Menu zu gelangen.

A	<b>TIME</b>
<b>S</b>	PROGRAM



2. Drehen Sie den Drehregler um auszuwählen welche Einstellungen Sie ändern möchten. (z.B.: Time auf Program)

A	TIME
<b>S</b>	<b>PROGRAM</b>



3. Drücken Sie den Drehregler um Kanal A zu wählen. Drehen Sie den Drehregler um Kanal B auszuwählen. (z.B.: A → B)

A	<b>A</b>	Max: 100%
<b>S</b>		On: 00:00

## Bedienungsanleitung

Deutsch



4. Drücken Sie den Drehregler um in das **"Maximum Brightness"** Menu zu gelangen. Drehen Sie den Drehregler um die Helligkeit anzupassen. (z.B. 100% auf 80%).

A	B	Max:	100%
S		On:	00:00



5. Drücken Sie den Drehregler um in das **"On Time"** zu gelangen. Drehen Sie den Drehregler um die Einschaltzeit zu programmieren, die Zeitänderung ist im 30mn Abstand. (z.B. 8h00 auf 8h30).

A	B	Max:	80%
S		On:	00:00



6. Drücken Sie den Drehregler erneut um in das **"Off Time"** Menu zu gelangen. Drehen Sie den Drehregler um die Ausschaltzeit zu programmieren, die Zeitänderung ist im 30mn Abstand. (z.B. 0h00 auf 22h30).

A	B	Max:	80%
S		Off:	00:00

7. Wenn Sie fertig sind, drücken und halten Sie den Drehregler 2 Sekunden lang, um aus dem Setup Modus zu gelangen.



Maxspect Ltd. haftet für alle Produkte des Maxspect™ Celestial LED- Beleuchtungssystems gegen Mängel in der Ausführung für einen Zeitraum von 12 Monaten ab dem Kaufdatum. Wenn ein Mangel während der Garantiezeit vorliegt, wird Maxspect Ltd das Produkt kostenlos nach eigenem Ermessen entweder reparieren (mit neu- oder Austauschteilen) oder das Produkt ersetzen (durch ein neues oder ein Austauschgerät).

DIE GARANTIE GILT NICHT FÜR PRODUKTE, DIE DURCH FALSCHER ANWENDUNG, VERÄNDERUNGEN, UNFÄLLE, UNSACHGEMÄSSE HANDHABUNG ODER EINGRIFFE BESCHÄDIGT WURDEN ODER AN DENEN REPARATUREN ODER REPARATURVERSUCHE VON NICHT-AUTORISIERTEN PERSONEN VORGENOMMEN WURDEN. ZU MÖGLICHEN SCHÄDEN, DIE NICHT VON DER GARANTIE ABGEDECKT SIND, GEHÖREN UNTER ANDEREM (ABER NICHT AUSSCHLIESSLICH) DER EINSATZ VON NACHGEMACHTEN LED-LEUCHTEN UND VERÄNDERUNGEN AN DEN SCHALTKREISEN, DIE VERMUTLICH SCHÄDEN AUFGRUND VON FALSCHER ANWENDUNG ODER MISSBRAUCH SIND.

### **HAFTUNGSAUSSCHLUSS FÜR FOLGE- UND ZUFALLSSCHÄDEN:**

Sie und alle anderen Nutzer der Produkte von Maxspect Ltd. haben kein Recht auf Entschädigung bei Folge – und Zufallsschäden, einschließlich und ohne Einschränkung bei Verlust des Geräts, Unannehmlichkeiten, Schäden am Privateigentum, Telefonanrufe, entgangenes Einkommen und entgangene Umsätze. Diese Garantie gesteht Ihnen bestimmte Rechte zu und Sie können zudem weitere Rechte haben, die von Land zu Land unterschiedlich sein können.

MAXSPECT LTD. GIBT KEINE GARANTIE UND ÜBERNIMMT KEINE VERANTWORTUNG FÜR DAS PRODUKT, WEDER AUSDRÜCKLICH NOCH IMPLIZIT, IN BEZUG AUF DIE QUALITÄT, LEISTUNG, MARKTGÄNGIGKEIT ODER EIGNUNG FÜR EINEN BESTIMMTEN ZWECK. DAHER WIRD DAS PRODUKT IN DER VORLIEGENDEN FORM („AS IS“) VERKAUFT UND SIE ALS KÄUFER TRAGEN DAS GESAMTE RISIKO IN BEZUG AUF QUALITÄT UND LEISTUNG.

MAXSPECT LTD IST IN KEINEM FALL HAFTBAR FÜR DIREKTE, INDIREKTE, ZUFÄLLIGE SCHÄDEN BZW. FOLGESCHÄDEN, DIE AUS EINEM FEHLER DES PRODUKTS ODER SEINER BEDIENUNGSANLEITUNG ENTSTEHEN KÖNNTEN.

Die oben dargelegte Garantie, Haftungsausschlüsse und Rechtsbehelfe sind exklusiv und ersetzen alle anderen mündlichen oder schriftlichen, ausdrücklichen oder impliziten Absprachen. Zu keinem Zeitpunkt sind die Maxspect Ltd. Händler, Agenten oder Mitarbeiter berechtigt, irgendwelche Änderungen, Erweiterungen oder Zusätze an dieser Garantie vorzunehmen.

Einige Länder erlauben den Ausschluss oder die Beschränkung von implizierten Garantien oder Haftungen für Zufalls- oder Folgeschäden nicht, so dass die oben genannten Beschränkungen oder Ausschlüsse eventuell nicht auf Sie zutreffen.

## Technische Angaben

<b>LED Modul</b>	<b>Abmessungen (L x B x H)</b>	
	<b>Celestial</b> <b>C35-F, C35-S, C35-A</b> <b>Celestial</b> <b>C70-F</b>	140mm × 85mm x 65mm (5.5" x 3.3" x 2.5") 150mm × 100mm x 85mm (6" x 4" x 3.3")
	<b>Gewicht</b>	
	<b>Celestial</b> <b>C35-F, C35-S, C35-A</b> <b>Celestial</b> <b>C70-F</b>	250g (0.6 lb)  400g (0.9 lb)

---

<b>Netzteil</b>	<b>Model</b>	GM50-240200-F (C35) GM601-240300 (C70)
	<b>Eingangsspannung / Strom</b>	1.5A/100-240vAC 50/60Hz
	<b>Ausgangsspannung / Strom</b>	24vDC 2A (C35) 24vDC 3A (C70)
	<b>Gewicht</b>	250g /0.6 lb (C35) 250g /0.8 lb (C70)

### Hinweis:

Für neusten technischen Daten, LED-Layout, LED-Typen und Farbspektrum besuchen Sie bitte unsere Internetseite unter [www.maxspect.com](http://www.maxspect.com)

Technische Angaben können sich ohne Vorankündigung ändern.

Gewicht und Abmessungen sind ungefähre Werte.

## ***Cher Client,***

Merci d'avoir acheté ce produit.

Pour des performances et une sécurité optimales, veuillez lire attentivement ces instructions.

### **Mémo utilisateur:**

Date d'achat :	_____
Nom du revendeur :	_____
Adresse du revendeur :	_____ _____
Site internet du revendeur :	_____
E-mail du revendeur :	_____
N° de téléphone du revendeur :	_____

Français

**Vous pouvez nous rejoindre sur facebook ou twitter !**



<https://www.facebook.com/Maxspect>



<http://twitter.com/maxspectled>

## Contenu de l'emballage

Merci de vérifier le contenu de votre emballage.

**Celestial Module LED**



**Alimentation**



**Support pour aquarium**





## Précautions d'utilisation

Avant toute utilisation du système d'éclairage LED Celestial Maxspect™, veuillez lire attentivement ce manuel d'utilisation. Soyez particulièrement attentifs aux consignes de sécurité qui suivent.

Gardez soigneusement ce manuel pour toute future utilisation.

### Avant d'utiliser le système d'éclairage LED Celestial Maxspect™

1. Si présent, retirez le film protecteur des lampes LED avant toute utilisation.
2. Ne regardez jamais directement dans la lumière quand vous mettez le système en marche. Une utilisation inappropriée de cet appareil augmente les risques de lésions oculaires.

Français

### Sécurité

1. **Alimentation électrique** – Ne dégradez pas le système de sécurité de la prise électrique à deux broches. La prise sécurisée possède deux broches rondes et une fiche ronde reliée à la terre. La fiche ronde assure votre sécurité. Si le connecteur électrique du système ne correspond pas à la prise murale, contacter un électricien pour le remplacement de la prise obsolète.
2. **Protection du cordon d'alimentation** – Le cordon doit être installé de sorte qu'il ne puisse pas être piétiné ou coincé par des objets placés sur ou contre lui. Ne tenez jamais la prise ou le cordon si vos mains sont humides et saisissez toujours le corps de la prise lors de la connexion ou déconnexion du cordon d'alimentation.
3. **Installation** – Le système doit être installé en intérieur uniquement et utilisé avec les fixations, cadre de montage, kit de suspension et accessoires fournis par le fabricant.

### Utilisation

1. **Utilisation** – Suivez toujours les instructions d'utilisation décrites dans ce manuel lorsque vous utilisez le système d'éclairage LED Celestial.
2. **Chaleur** – L'appareil doit être éloigné de toute source de chaleur comme des radiateurs et ne doit pas être exposé à des sources de chaleur importante comme le feu ou les rayons de soleil.
3. **Humidité** – Afin de réduire tout risque de choc électrique, maintenez cet appareil à l'abri de la pluie et de toute source d'humidité.
4. **Ventilation** – L'appareil doit être disposé de façon à ce que son emplacement et sa position n'interfèrent pas avec sa propre ventilation.
5. **Magnétisme** – L'appareil doit être disposé à l'écart de tout équipement ou dispositif qui génère un champ magnétique important.
6. **Nettoyage** – Nettoyez uniquement à l'aide d'un chiffon sec..

## Fixation du Système d'Éclairage LED Celestial

Avant de connecter le module LED à l'alimentation, assemblez tout d'abord le système en utilisant le support fourni.

### 1. Assemblage du support.

Montez le support en insérant le rail à l'endroit prévu à cet effet sur le Module LED Celestial, comme illustré dans le schéma suivant.



### 2. Serrez les vis manuelles.

Serrez les vis afin d'assurer la position désirée du support.

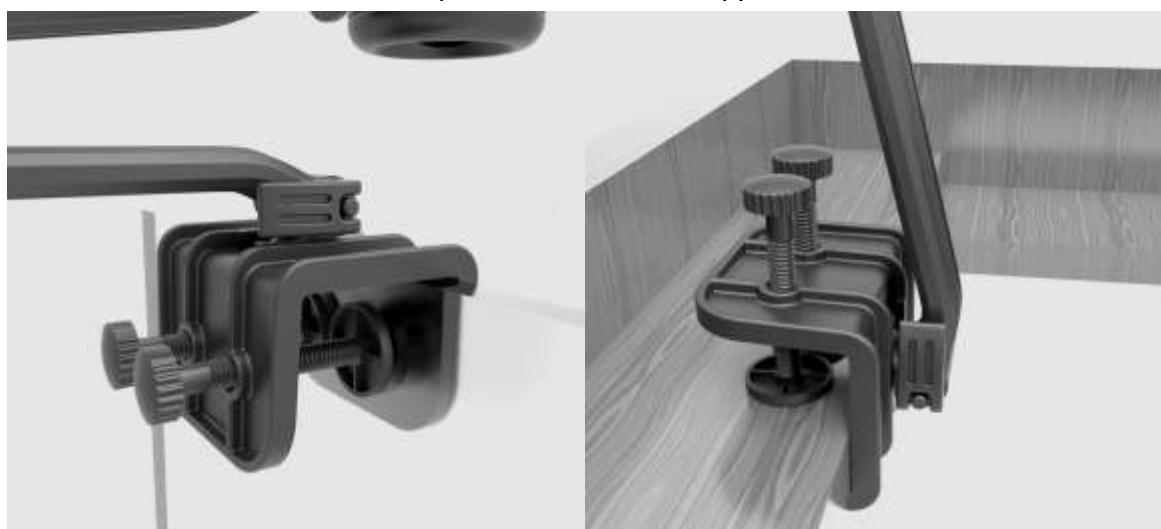

## 3. Ajustement de l'angle désiré.



Français



# Instructions d'utilisation

## Opérations de base

Suivez les instructions suivantes pour utiliser et la programmer le module LED Celestial.

### Remarque

**Le module LED s'allume automatiquement lorsque l'alimentation est connectée, et s'éteint lorsque l'alimentation est coupée.**

Lorsque l'alimentation est rétablie, le module Led revient automatiquement à la sauvegarde précédente, il garde également le niveau d'intensité sélectionné pour tous les canaux LED.

**Lorsque l'alimentation est connectée, le logo Maxspect sera affiché avec la version de firmware.**

MAXSPECT<sub>c1.1</sub>

## Permutation entre le mode Manuel et Automatique



1. Appuyez et maintenez le bouton de contrôle durant 2 secondes pour basculer entre les 2 modes. L'écran LCD affichera « M » et « A » en fonction de votre choix.

### Mode Manuel:

<b>M</b>	A: 100%	B: 100%
	C: 100%	D: 100%

### Mode Automatique:

<b>A</b>	12: 30
A: 100%	B: 100%

## Instructions d'utilisation

### Mode Manuel "M"

En mode manuel, vous pouvez régler la luminosité des deux canaux en utilisant la molette de commande.



1. Appuyez une fois sur la molette de commande pour entrer dans la configuration. Le canal « A » sera sélectionné par défaut. Tournez la molette pour régler la luminosité du canal « A ».

<b>M</b>	A: <b>100%</b>	B: 100%
	C: 100%	D: 100%



2. Appuyez de nouveau sur la molette de commande pour passer au canal « B ». Tournez la molette pour régler la luminosité de ce canal. Répétez la même chose pour les autres canaux.

<b>M</b>	A: 60%	B: <b>100%</b>
	C: 100%	D: 100%

3. Appuyez une fois de plus sur la molette de commande pour quitter ce menu.
4. Notez que les modèles C35-F/C70-F ont 4 canaux, tandis que les modèles C35-S/C35-A ont 2 canaux. L'interface sera légèrement différent comme illustré ci-dessous.

<b>M</b>	A: 100%
	B: 100%

Français

## Mode Automatique "A"

En mode automatique, vous pouvez programmer votre propre profil de photopériode en paramétrant 'On Time', 'Off Time' et 'Maximum Brightness' pour chaque canal.

Le canal se met automatiquement sur 'On Time' et commence par 0% de luminosité et augmente lentement sur une période de 30 minutes pour atteindre le 'Maximum Brightness' programmé pour ce canal. Ensuite, la luminosité diminuera sur une période de 30 minutes à partir de l'heure de 'Off Time' programmée, puis s'éteindra.

Français

Par exemple, le tableau suivant montre comment vous pouvez programmer les canaux pour que le canal A s'allume à 08h00, atteint 80% de luminosité à 08h30 jusqu'à 16h30, puis diminuera pour s'éteindre à 17h00. De même, le canal B s'allumera à 8h30, atteindra 60% de luminosité à 09h00 jusqu'à 23h00, puis diminuera pour s'éteindre à 23h30.

	Maximum Brightness	On Time	Off Time
<b>Canal A</b>	80%	08:00	16:30
<b>Canal B</b>	65%	08:30	23:00

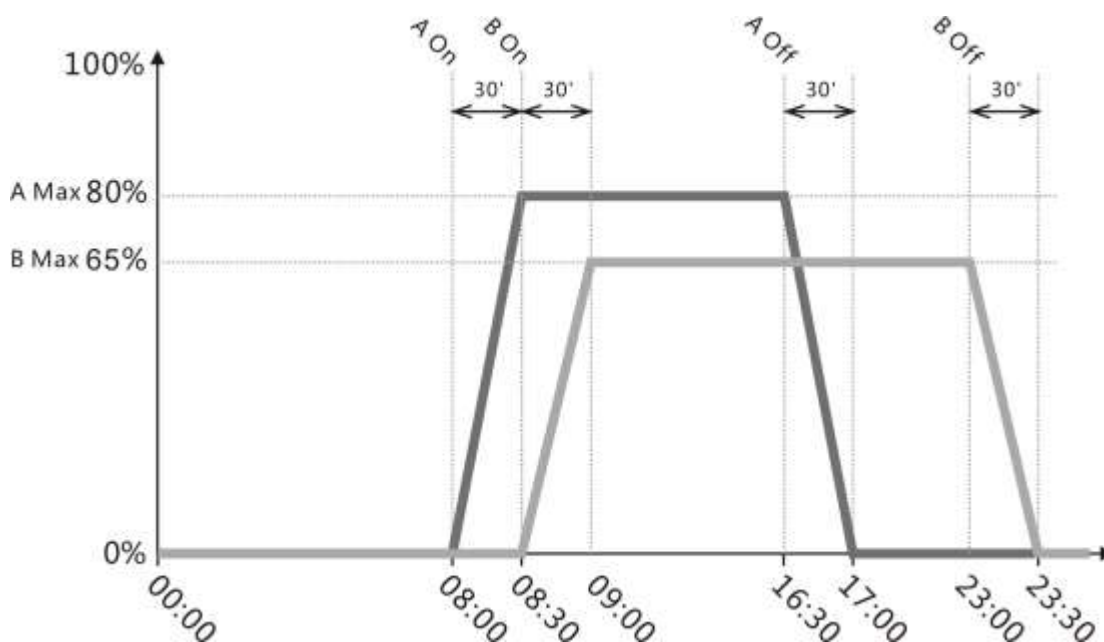

# Instructions d'utilisation

## Mode automatique – Réglage de l'heure

1. Quand vous êtes dans le mode réglage d'horloge, le chiffre de l'heure est sélectionné par défaut.

A TIME:

S 06: 30



2. Tourner le bouton de contrôle pour régler l'heure. (p. ex. 06:30 à 08:30)

A TIME:

S 08: 30



3. Appuyez sur le bouton de contrôle pour sélectionner le réglage des minutes. Tournez le bouton de contrôle pour régler les minutes. (p. ex. 08:30 à 08:45)

A TIME:

S 08: 30

4. Une fois terminé, appuyez 2 secondes sur le bouton de contrôle pour quitter le menu de sélection.

Français

## Instructions d'utilisation

### Mode automatique – Programmation de la Photopériode



1. Appuyez sur la molette de commande pour entrer dans le menu de configuration.

A **TIME**  
S PROGRAM



2. Tournez le bouton de contrôle pour choisir les paramètres que vous souhaitez modifier. (p. ex. Time ou Program)

A TIME  
S **PROGRAM**



3. Appuyez de nouveau sur la molette de commande pour sélectionner le réglage, le canal (A) est sélectionné. Tournez la molette pour changer de canal. (e.g. A → B)

A **A** Max: 100%  
S On: 00:00



## Instructions d'utilisation



4. Appuyez sur la molette de commande pour modifier le réglage de la luminosité. Tournez la molette pour régler la luminosité (par exemple 100% → 80%).

A	B	Max:	100%
S		On:	00:00



5. Appuyez sur la molette de commande pour régler l'heure. Tournez la molette pour régler le '**On Time**', le temps est incrémenté toutes les 30 minutes. (p. ex. 00h00 → 08h30)

A	B	Max:	80%
S		On:	00:00



6. Appuyez à nouveau sur la molette de commande pour le réglage de '**Off Time**'. Tournez la molette pour régler l'extinction, le temps est incrémenté toutes les 30 minutes. (p. ex. 00h00 → 22h30)

A	B	Max:	80%
S		Off:	00:00

7. Une fois terminé, appuyez 2 secondes sur le bouton de contrôle pour quitter le menu de sélection.

Français

# Instructions d'utilisation

Français

## Limite de garantie

Maxspect Ltd. garantit tous les produits du système d'éclairage LED Celestial Maxspect™ contre les défauts de fabrication ou de matériaux pendant une période de 12 mois à compter de la date d'achat. Si un défaut est révélé au cours de la période de garantie, Maxspect Ltd., à sa convenance, réparera (avec des pièces neuves ou de rechanges) ou remplacera (par une unité nouvelle ou réparée) le produit, gratuitement.

LA GARANTIE NE S'APPLIQUE PAS AU PRODUIT S'IL A ÉTÉ ENDOMMAGÉ PAR UNE MAUVAISE UTILISATION SUITE À UNE MAUVAISE MANIPULATION, UNE INSTALLATION INCORRECTE, AU TRANSPORT OU POUR DES TENTATIVES DE RÉPARATION PAR DES PERSONNES NON AUTORISÉES. DES EXEMPLES DE DOMMAGES NON COUVERTS PAR LA GARANTIE INCLUENT, MAIS NE SE LIMITENT PAS A L'UTILISATION DE LED DE REMPLACEMENT ET MODIFICATION DES CIRCUITS DONT POURRAIENT RESULTER DES DOMMAGES DUS A UNE MAUVAISE UTILISATION OU UN MAUVAIS TRAITEMENT.

Français

### **EXCLUSION DE DOMMAGES IMMATERIELS OU ACCESSOIRES :**

Maxspect Ltd. ne peut en aucun cas être tenu pour responsable des dommages directs, indirects ou conséquents comprenant mais non limités à : la perte de l'usage de l'unité, désagréments, dégâts matériels à des biens personnels, appels téléphoniques, perte de revenus ou de salaire. Cette garantie vous donne des droits légaux spécifiques ainsi que d'autres droits éventuels, qui peuvent varier d'un pays à l'autre.

MAXSPECT LTD. N'OFFRE AUCUNE GARANTIE, QU'ELLE SOIT EXPRESSE OU IMPLICITE, QUANT A LA QUALITE DES PRODUITS, LES PERFORMANCES, SA COMMERCIALISATION OU L'ADAPTATION A UN USAGE DIFFERENT DE CELUI AUQUEL IL EST DESTINE. EN CONSEQUENCE, CES PRODUIT SONT VENDUS «TELS QUELS», ET VOUS, ACHETEUR, ASSUMEZ ENTIEREMENT LES RISQUES QUANT A SA QUALITE ET SES PERFORMANCES.

EN AUCUN CAS MAXSPECT LTD NE SERA RESPONSABLE DE DOMMAGES DIRECTS, INDIRECTS, PARTICULIERS, ACCESSOIRES OU CONSECUTIFS RESULTANTS DE TOUT DEFAUT DU PRODUIT OU DE SA DOCUMENTATION.

LA GARANTIE, L'EXCLUSION ET LES MESURES PREVUES PRECEDEMMENT SONT EXCLUSIVES, ET REMPLACENT TOUTES LES AUTRES, ORALES OU ECRITES, EXPLICITES OU IMPLICITES. En aucun cas, des revendeurs, agents ou employés de Maxspect Ltd. ne seront autorisés à apporter des modifications, extensions ou ajouts à cette garantie.

Certains pays ne permettent pas l'exclusion ou la limitation des garanties implicites ou la responsabilité pour les dommages directs ou indirects, de sorte que la limitation ou l'exclusion de cette garantie peut ne pas vous être appliqué.

## Spécifications

<b>Module LED</b>	<b>Dimensions (L x l x H)</b>	
	<b>Celestial C35-F, C35-S, C35-A</b>	140mm × 85mm x 65mm (5.5" x 3.3" x 2.5")
	<b>Celestial C70-F</b>	150mm × 100mm x 85mm (6" x 4" x 3.3")
	<b>Poids</b>	
	<b>Celestial C35-F, C35-S, C35-A</b>	250g (0.6 lb)
	<b>Celestial C70-F</b>	400g (0.9 lb)

Français

---

<b>Alimentation</b>	<b>Model</b>	GM50-240200-F (C35) GM601-240300 (C70)
	<b>Tension / courant d'entrée</b>	1.5A/100-240vAC 50/60Hz
	<b>Tension / courant de sortie</b>	24vDC 2A (C35) 24vDC 3A (C70)
	<b>Poids</b>	250g /0.6 lb (C35) 250g /0.8 lb (C70)

### Remarque:

Pour les dernières spécifications sur la disposition, du type et du spectre de couleurs des LED, veuillez-vous rendre sur notre site Web à [www.maxspect.com](http://www.maxspect.com)

Les informations techniques peuvent être sujettes à changement sans préavis

Poids et dimensions sont approximatifs.

## ***Gentile Cliente,***

Grazie e complimenti per aver acquistato il nostro prodotto .

Per ottimizzare prestazioni e sicurezza, vi preghiamo di leggere attentamente le istruzioni

### **Utente memo:**

Data di acquisto: \_\_\_\_\_

Rivenditore: \_\_\_\_\_

Indirizzo del rivenditore: \_\_\_\_\_

Sito web del rivenditore: \_\_\_\_\_

E-mail del rivenditore: \_\_\_\_\_

Telefono del rivenditore: \_\_\_\_\_

Italiano

### **Puoi seguirci su facebook e twitter!**



<https://www.facebook.com/Maxspect>



<http://twitter.com/maxspectled>

## Contenuto Scatola

**Per favore verifica il contenuto della scatola:**

**Modulo LED Celestial**



**Alimentatore**



**Supporti bordo vasca**



Prima di utilizzare il sistema d'illuminazione a LED Maxspect™ Celestial Vi preghiamo di leggere attentamente le istruzioni. Far particolare attenzione e seguire i suggerimenti di sicurezza elencati di seguito. Successivamente tenere questo manuale a portata di mano per riferimento futuri

### Prima di utilizzare il sistema d'illuminazione a LED Maxspect™

1. Rimuovere eventuali sacchetti di plastica e materiale d'imballaggio che proteggono l'apparecchio.
2. Non guardare mai direttamente i LED accesi. L'uso improprio di questo apparecchio aumenta i pericoli per gli occhi.

### Sicurezza

1. **Alimentazione** – non annullare sulla spina la messa a terra. Se la spina non si inserisce nella presa, consultare un elettricista per la sostituzione della presa con una adatta.
2. **I cavi di alimentazione** – I cavi di alimentazione devono essere disposti in modo che non possano essere calpestati o schiacciati da oggetti posti sopra o contro di essi. Mai prendere in mano la spina o il cavo se la vostra mano è bagnata; afferrare sempre il corpo della spina per collegare o scollegare la stessa.
3. **Installazione** – Installare solo all'interno e mai all'esterno di locali; utilizzare gli accessori di montaggio previsti e specificati dal produttore.

### Funzionamento

1. **Funzionamento** – Seguire sempre le istruzioni operative contenute nel presente manuale quando si utilizza questo sistema di illuminazione a LED Celestial.
2. **Calore** – L'apparecchio deve essere posto lontano da fonti di calore come termosifoni, non esporre a calore eccessivo come luce solare, fuoco o simili.
3. **Umidità** – Per ridurre il rischio di incendi o scosse elettriche non esporre questo apparecchio alla pioggia, umidità, gocciolamenti o spruzzi d'acqua.
4. **Ventilazione** – L'apparecchio deve essere posto in modo che la sua collocazione o posizione non interferisca con l'adeguata ventilazione.
5. **Magnetismo** – L'apparecchio deve essere collocato lontano da apparecchiature o dispositivi che generano forte magnetismo.
6. **Pulizia** – Pulire frequentemente solo con un panno asciutto e avendo cura di scollegare dall'alimentazione elettrica.

## Montaggio del sistema d'illuminazione a LED Celestial

Prima di collegare i moduli LED all'alimentazione montare completamente il sistema utilizzando il supporto fornito.

### 1. Assemblaggio Supporti.

Montare il supporto inserendolo nei al lato del modulo a LED Celestial, come illustrato nello schema seguente:



### 2. Fissaggio del supporto.

Una volta inseriti i supporti e distanziati alla misura desiderata avvitare le viti in dotazione e serrare per bloccare il supporto.

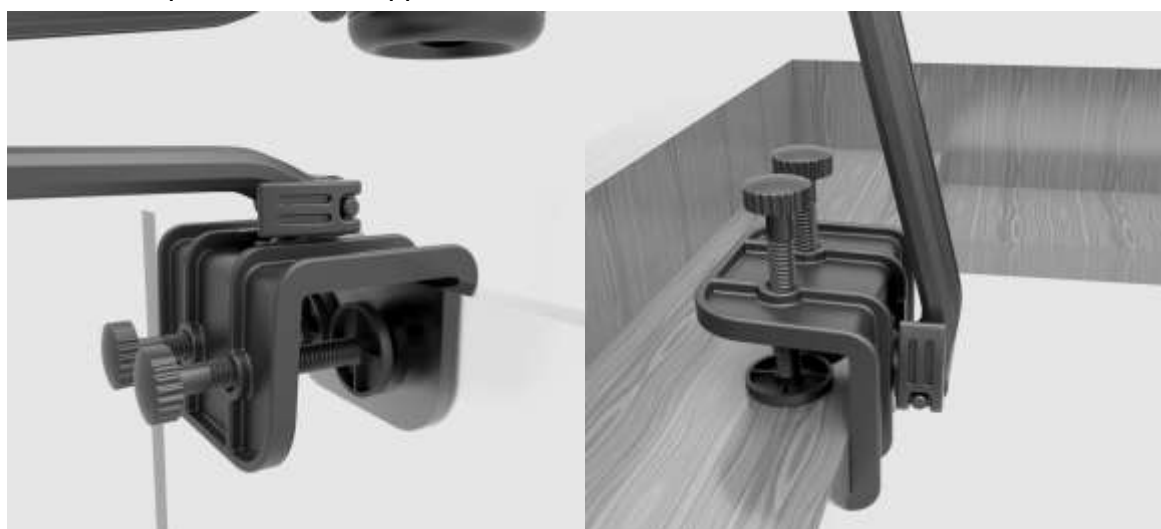



## 3. Regolare l'angolo.



Italiano



## Operazioni di base

Seguire le istruzioni riportate di seguito per accendere e programmare il modulo a LED Celestial.

### Nota

**Il modulo a LED si accende automaticamente non appena alimentato.**

Quando l'alimentazione viene a mancare e poi ripristinata, il modulo a LED riprende le impostazioni precedenti il black-out.

**Una volta collegato alla rete elettrica sul display apparirà il logo Maxspect e la versione del firmware.**

MAXSPECT<sub>c1.1</sub>

Italiano

## Passaggio tra modalità Manuale e Automatica



1. Premere e tenere premuto per 2 secondi la manopola di controllo per passare tra le 2 modalità. Il pannello LCD visualizzerà "M" e "A" di conseguenza.

### Modalità manuale:

<b>M</b>	A: 100%	B: 100%
	C: 100%	D: 100%

### Modalità automatica:

<b>A</b>	12: 30	
	A: 100%	B: 100%

### Modalità Manuale "M"

In modalità manuale, l'utente può regolare la luminosità dei due canali utilizzando la manopola di controllo.



1. Premere la manopola di controllo una volta per accedere al setup. Verrà selezionato il canale A come impostazione predefinita. Ruotare la manopola di controllo per regolare luminosità del canale "A".

<b>M</b>	A: <b>100%</b>	B: 100%
	C: 100%	D: 100%

Italiano



2. Premere la manopola di controllo un'altra volta per passare al canale "B". Ruotare la manopola di controllo per regolare luminosità del canale "B". Ripetere lo stesso per altri canali.

<b>M</b>	A: 60%	B: <b>100%</b>
	C: 100%	D: 100%

3. Premere la manopola di controllo un'altra volta per uscire.

4. Nota: i modelli C35-F/C70-F hanno 4 canali, mentre I modelli C35-S/C35-A hanno solo 2 canali, l'interfaccia di conseguenza avrà un aspetto differente come illustrato di seguito.

<b>M</b>	A: 100%
	B: 100%

## Modalità Automatica "A"

In modalità automatica, gli utenti possono programmare il profilo di fotoperiodo personalizzato su ciascun canale usando le impostazioni: **On Time**, **Off Time** e **Maximum Brightness**.

Il canale si accenderà automaticamente all'ora impostata come **On Time**, la luminosità partirà da 0% e nei 30 minuti successivi andrà ad aumentare lentamente per raggiungere la **Maximum Brightness (luminosità massima)** impostata sul canale. La luminosità inizierà a diminuire lentamente a partire dall'ora impostata come **Off Time**, il canale si spegnerà automaticamente dopo 30 minuti.

Per esempio, la seguente tabella illustra come possiamo programmare i canali in modo da avere l'accensione del Canale A alle ore 8:00, il raggiungimento e permanenza della luminosità all'80% dalle 8:30 alle 16:30, di seguito la diminuzione della luminosità a partire dalle 16:30 per spegnersi alle ore 17:00. Allo stesso modo il Canale B si accenderà alle ore 8:30, raggiungerà la luminosità impostata al 60% alle 9:00, rimarrà al 60% fino le 23:00, alle 23.00 comincerà a diminuire per spegnersi alle 23:30.

	Maximum Brightness	On Time	Off Time
<b>Kanal A</b>	80%	08:00	16:30
<b>Canale B</b>	65%	08:30	23:00

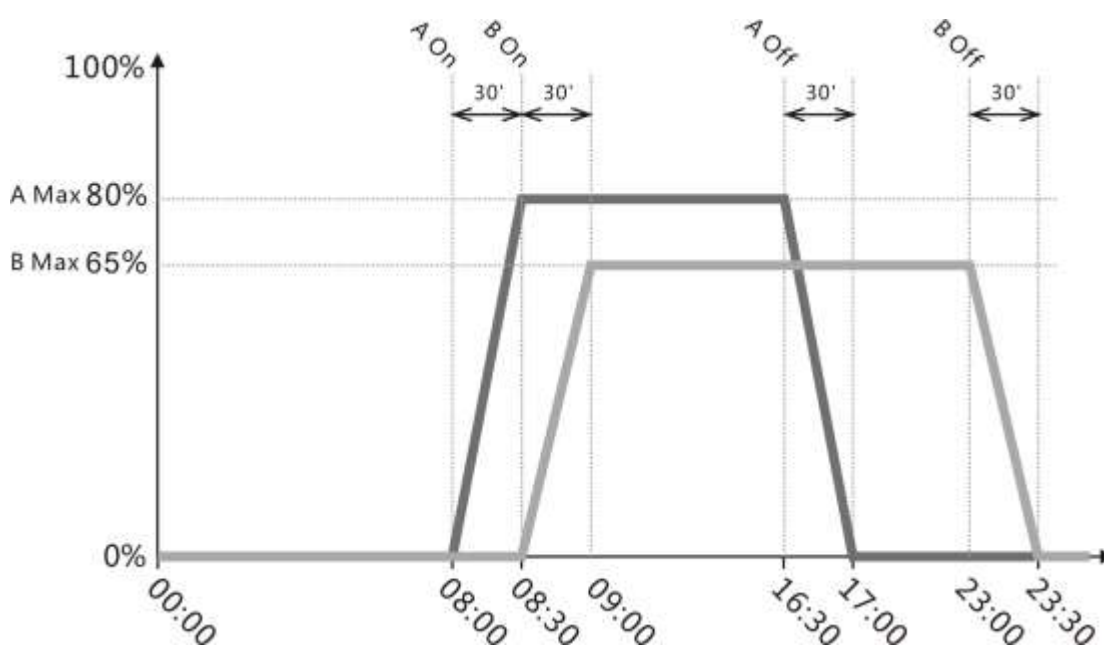

### Modalità Automatica – Settaggio dell'orologio

1. Una volta che si è sulla modalità di programmazione dell'orologio lampeggia la cifra dell'ora predefinita.

A TIME:

S 06: 30



2. Ruotare la manopola di controllo per settare l'ora. (ad es. 06:30 → 08:30)

A TIME:

S 08: 30



3. Premere la manopola di controllo per passare a regolare i minuti. Ruotare la manopola di controllo per regolare i minuti.

A TIME:

S 08: 30

4. Una volta terminata la regolazione dell'ora premere la manopola di controllo e tenerla premuta per 2 secondi per tornare al setup dalla programmazione.

### Modalità Automatica – Programmazione del fotoperiodo



1. Premere la manopola di controllo una volta per accedere al setup.

A	<b>TIME</b>
S	PROGRAM



2. Ruotare la manopola per selezionare tra le impostazioni da modificare (ad es. Time → Program)

A	TIME
S	<b>PROGRAM</b>



3. Premere la manopola di controllo un'altra volta per selezionare l'impostazione, il primo canale (A) è selezionato. Ruotare la manopola di controllo per passare da un canale all'altro (ad es. A → B)

A	<b>A</b>	Max: 100%
S		On: 00:00

## Istruzioni Per L'Uso



4. Premere la manopola di controllo to per modificare le impostazioni di luminosità. Ruotare la manopola di controllo per impostare la luminosità (ad es. 100% → 80%)

A	B	Max:	100%
S		On:	00:00



5. Premere la manopola di controllo per passare alle impostazioni di ora di accensione **On Time**. Ruotare la manopola di controllo per impostare l'ora di accensione, il tempo incrementa ogni 30 minuti (ad es. 00:00 → 08:30)

A	B	Max:	80%
S		On:	00:00



6. Premere la manopola di controllo di nuovo per passare alle impostazioni di ora di spegnimento **Off Time**. Ruotare la manopola di controllo per impostare l'ora di spegnimento, il tempo incrementa ogni 30 minuti (ad es. 00:00 → 22:30)

A	B	Max:	80%
S		Off:	00:00

7. Una volta portata a termine la programmazione premere tenere premuta la manopola di controllo per 2 secondi per uscire.

Italiano





## Termini di garanzia

Maxspect Ltd. garantisce tutti i Sistemi di Illuminazione a LED Maxspect™ Celestial per i difetti di fabbricazione, per un periodo di 12 mesi dalla data di acquisto. Se un difetto di produzione si presenta durante il periodo di garanzia, Maxspect Ltd. a sua discrezione, riparerà (usando componenti nuovi o ricostruiti) o sostituirà (con una nuova unità o rigenerate) il prodotto senza alcun costo.

LA GARANZIA NON SI APPLICA AL PRODOTTO SE È STATO DANNEGGIATO DA USO IMPROPRIO, ALTERAZIONE, INCIDENTE, USO O FUNZIONAMENTO IMPROPRIO, SE SONO EFFETTUATE RIPARAZIONI NON AUTORIZZATE.

### **ESCLUSIONE DEI DANNI INDIRETTI E ACCIDENTALI:**

L'utilizzatore dei prodotti della Maxspect Ltd. non ha diritto ad alcun risarcimento danni diretti o indiretti, senza limitazione, derivanti da: disagi, danni ai beni personali, telefoni, le perdite materiali ecc... Questa garanzia conferisce diritti legali specifici.

MAXSPECT LTD. NON FORNISCE ALCUNA GARANZIA O DICHIARAZIONE, ESPLICITA O IMPLICITA, RISPETTO ALLA QUALITÀ DEL PRODOTTO, PRESTAZIONI, COMMERCIALIZZABILITÀ O IDONEITÀ PER UNO SCOPO DIVERSO DA QUELLO INDICATO. DI CONSEGUENZA QUESTO PRODOTTO VIENE VENDUTO, COSÌ COME È E L'ACQUIRENTE SI ASSUME IL RISCHIO SULLA QUALITÀ E PRESTAZIONI.

In nessun caso la MAXSPECT LTD potrà essere ritenuta responsabile per danni diretti, indiretti, speciali, incidentali o conseguenti derivanti da qualsiasi problema del prodotto o la documentazione.

La garanzia, ed i rimedi di cui sopra sono esclusivi e sostituiscono tutti gli altri, orali o scritti, espressi o impliciti. In nessun caso qualsiasi commerciante, agente, impiegato è autorizzato ad apportare modifiche, estensioni o aggiunte alla presente garanzia.

Alcuni stati non consentono l'esclusione o la limitazione delle garanzie implicite o la responsabilità per danni incidentali o consequenziali, pertanto la suddetta limitazione o esclusione potrebbe non applicarsi a Voi.

Italiano

## Specifications

<b>LED Module</b>	<b>Dimensioni (L x W x H)</b>	
	<b>Celestial C35-F, C35-S, C35-A</b>	140mm × 85mm x 65mm (5.5" x 3.3" x 2.5")
	<b>Celestial C70-F</b>	150mm × 100mm x 85mm (6" x 4" x 3.3")
	<b>Weight</b>	
	<b>Celestial C35-F, C35-S, C35-A</b>	250g (0.6 lb)
	<b>Celestial C70-F</b>	400g (0.9 lb)

## Italiano

<b>Alimentatore</b>	<b>Modello</b>	GM50-240200-F (C35) GM601-240300 (C70)
	<b>Voltaggio ingresso / Corrente</b>	1.5A/100-240vAC 50/60Hz
	<b>Voltaggio uscita / Corrente</b>	24vDC 2A (C35) 24vDC 3A (C70)
	<b>Peso</b>	250g /0.6 lb (C35) 250g /0.8 lb (C70)

### Nota:

Per aggiornamenti relativi alla configurazione dei LED, tipi e colori dello spettro, siete pregati di consultare il nostro sito web [www.maxspect.com](http://www.maxspect.com)

Le specifiche sono soggette alle modifiche senza alcun preavviso.

Peso e dimensioni sono approssimativi.

## ***Prezado Cliente,***

Obrigado por adquirir este produto.

Para um melhor desempenho e segurança, por favor leia cuidadosamente estas instruções.

### **User Memo:**

Data da Compra:

---

Nome Loja:

---

Endereço Loja:

---

---

Website Loja:

---

Email Loja:

---

Telefone Loja:

---

Português

**Por favor, visite-nos no Facebook ou Twitter!**



<https://www.facebook.com/Maxspect>



<http://twitter.com/maxspectled>

## Conteúdo da Embalagem

Por favor, analise o conteúdo da embalagem.

**Celestial modulo LED**



**Fonte de Energia**



**Suporte**



Antes de usar seu Sistema de Iluminação LED Maxspect™ Celestial por favor leia este manual de instruções cuidadosamente. Tenha cuidado e siga corretamente todas as instruções descritas.

Mantenha sempre ao alcance este manual para eventual consulta.

### Antes de usar seu Sistema de Iluminação LED Maxspect™

1. Remova todo o plástico e material de proteção da embalagem.
2. Nunca olhe diretamente para os leds quando você ligar a luminária. O uso incorreto do sistema poderá acarretar problemas de visão.

### Segurança

1. **Fonte de energia** - Não anule a finalidade de segurança da tomada ou do tipo terra. Uma tomada polarizada possui duas lâminas, uma mais larga que a outra. Uma tomada de tipo terra tem duas lâminas e um terceiro pino de aterramento. A lâmina larga ou o terceiro pino são fornecidos para sua segurança. Se a tomada não encaixar na sua tomada, consulte um profissional da área para a substituição da tomada obsoleta.
2. **Proteção do cabo de energia** – Os cabos de alimentação devem ser instalados em locais que não são susceptíveis de serem pisados ou esmagados por elementos colocados sobre ou contra eles. Nunca segure a tomada ou o cabo se sua mão estiver molhada.
3. **Instalação** – Instale somente em ambientes fechados e/ou cobertos, usar os acessórios, peças de montagem, kit pendant e acessórios fornecidos e especificados pelo fabricante.

Português

### Em funcionamento:

1. **Funcionamento** – Siga sempre as instruções de operação estabelecidas neste manual ao usar seu Sistema de Iluminação LED Celestial Sistema de Iluminação LED.
2. **Calor** – O aparelho deve ser colocado longe de fontes de calor, como radiadores, e não expor ao calor excessivo, como luz solar, fogo ou algo semelhante.
3. **Umidade** – Para reduzir o risco de incêndio ou choque elétrico, não exponha o aparelho à chuva, umidade ou respingos.
4. **Ventilação** – O aparelho deve ser posicionado de modo que a sua localização ou posição não interfira com uma ventilação adequada.
5. **Magnetismo** – O aparelho deve ser mantido longe de equipamentos ou fontes que possam gerar forte magnetismo.
6. **Limpeza** – Limpe sempre com um pano seco.

## Montagem do sistema Celestial LED Lighting System

Antes de ligar o módulo de LED com a fonte de alimentação, monte o sistema, usando o(s) suporte(s) fornecido.

### 1. Montando o suporte.

Monte o suporte, inserindo os trilhos situados ao lado do módulo de LED, tal como ilustrado na figura a seguir.



### 2. Prendendo os parafusos de fixação.

Aperte os parafusos de fixação para assegurar a posição estabelecida ao suporte.

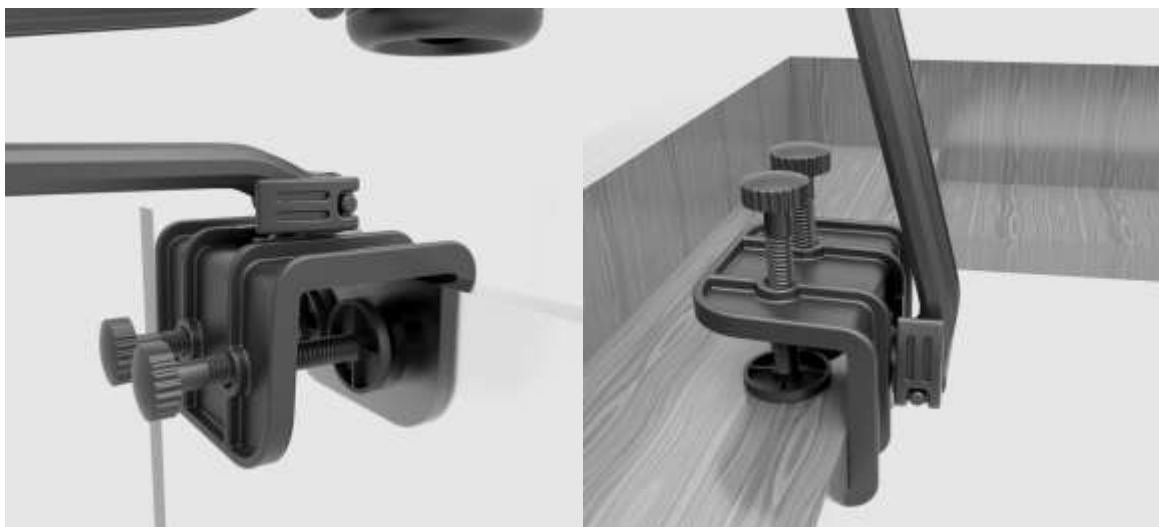

## 3. Ajuste o ângulo.



Português



# Instruções de funcionamento

## Operações básicas

Siga as instruções abaixo para operar e programar o módulo de LED Celestial.

### ATENÇÃO

**O módulo de LED liga-se automaticamente quando a alimentação é conectada, e, desliga quando a energia é cortada.**

Quando a energia é restabelecida, o módulo de LED irá restaurar a configuração anterior que foi salva automaticamente, se a última colocação no modo Manual, Preset Mode ou Automática, e no nível de intensidade de todos os canais de LED de quando a energia foi cortada.

**O logotipo Maxspect será exibido com a versão do software da empresa quando a energia estiver ligada.**

MAXSPECT<sub>c1.1</sub>

## Alternar entre o modo Manual e Automático.



1. Pressione e segure o botão de controle por 2 segundos para alternar entre os dois modos. O painel de LCD exibirá "M", e "A" em conformidade.

### Modo manual:

<b>M</b>	A: 100%	B: 100%
	C: 100%	D: 100%

### Modo automatico:

<b>A</b>	12: 30	
	A: 100%	B: 100%



# Instruções de funcionamento

## Modo manual "M"

Sob o modo manual, o usuário pode ajustar o brilho dos dois canais usando o botão de controle.



1. Pressione o botão de controle uma vez para entrar na configuração. Canal 1 será selecionada por padrão. Gire o dial para ajustar o brilho.

<b>M</b>	A: <b>100%</b>	B: 100%
	C: 100%	D: 100%



2. Pressione o botão dial novamente para selecionar o canal B. Então, gire para ajustar o brilho.

<b>M</b>	A: 60%	B: <b>100%</b>
	C: 100%	D: 100%

3. Pressione o controle Dial mais uma vez para sair.

4. Note-se que os modelos C35-F/C70-F tem 4 canais, enquanto os modelos C35-S/C35-A só tem 2 canais, a interface ficaria um pouco diferente, como ilustrado abaixo.

<b>M</b>	A: 100%
	B: 100%

# Instruções de funcionamento

## Modo automatico "A"

No modo automático, o usuário pode programar o seu próprio perfil de foto-período usando o **On Time**, **Off Time** e **Maximum Brightness** de cada canal.

A intensidade luminosa, aumentará com um intervalo mínimo de 30 minutos até atingir a intensidade luminosa programada, essa intensidade é definida em porcentagem de cada canal. O declínio da intensidade luminosa se dá da mesma maneira porém de forma contrária.

Por exemplo, a tabela a seguir demonstra como você pode programar os canais de tal forma que Canal A acenderá a partir de 08h00, chega o brilho de 80% às 8h30 e permanecem lá até 04:30, depois diminuirá até desligar às 5:00 da tarde. Da mesma forma, o Canal B acenderá as 8h30, chega a 60% de brilho às 9:00 horas e permanecem lá até às 11:00 horas, em seguida, diminuir até desligar às 11:30 hs.

	Maximum Brightness	On Time	Off Time
Canal A	80%	08:00	16:30
Canal B	65%	08:30	23:00

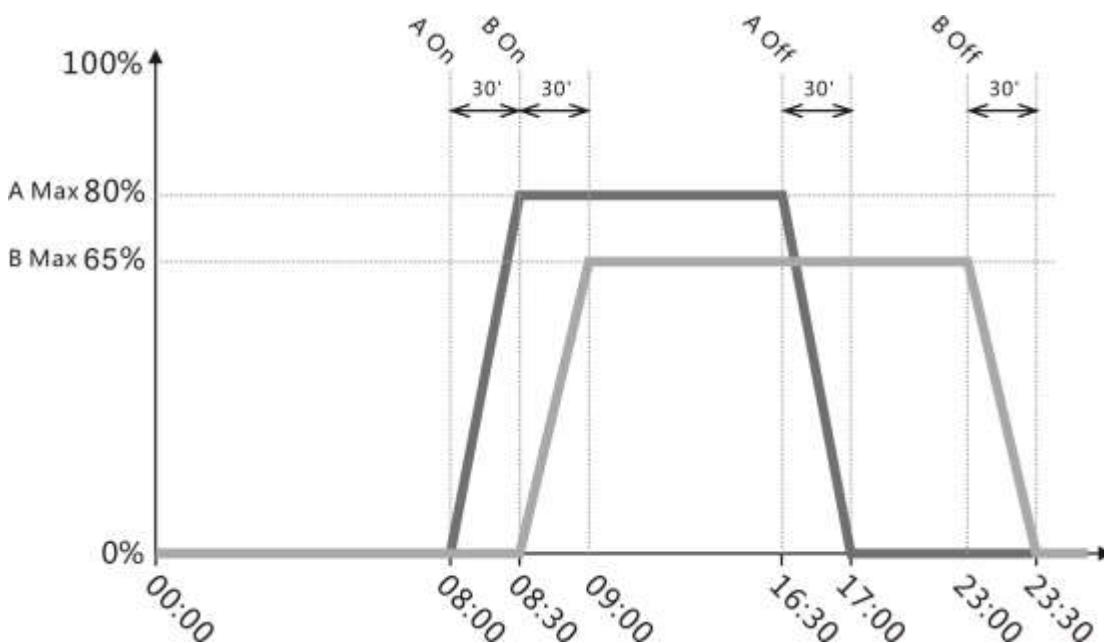

## Instruções de funcionamento

### Modo Automático – Definindo a hora.

1. Uma vez que você está no modo de ajuste do relógio, o dígito da hora é selecionado por padrão.

A TIME:

S 06: 30



2. Gire o botão para selecionar a hora (ex. 06:30 → 08:30)

A TIME:

S 08: 30



3. Aperte o botão para mudar para a opção dos minutos. Então, gire o botão para configurar os minutos.

A TIME:

S 08: 30

4. Quando finalizar, aperte o botão por 2 segundos para sair do setup.

Português

## Instruções de funcionamento

### Modo automático – programando o fotoperíodo



1. Pressione o botão do dial para entrar no setup.

A	<b>TIME</b>
S	PROGRAM



2. Gire o botão selector para seleccionar qual configuração deseja modificar. (e.g. Time → Program)

A	TIME
S	<b>PROGRAM</b>



3. Pressione o botão novamente para seleccionar a configuração, o primeiro canal "A" é seleccionado, então, gire o botão para seleccionar o canal "B". (e.g. A → B)

A	<b>A</b>	Max: 100%
S		On: 00:00

## Instruções de funcionamento



4. Pressione o botão selector para entrar na configuração de brilho (intensidade luminosa). Gire-o então para alterar a sua configuração. (e.g. 100% → 80%)

A	<b>B</b>	Max: 100%
<b>S</b>		On: 00:00



5. Pressione o botão selector para configurar o acendimento. Gire o botão para ajustar a hora que deseja iniciar a iluminação. Qualquer modificação depois de marcada o horário de acendimento só pode ser seleccionada a cada 30 minutos. (e.g. 00:00 → 08:30)

A	<b>B</b>	Max: 80%
<b>S</b>		On: 00:00



6. Pressione o botão selector para ajustar o horário o qual sera desligada a iluminação. A configuração é a mesma que o acendimento, podendo alterar a cada 30 minutos. (e.g. 00:00 → 22:30)

A	<b>B</b>	Max: 80%
<b>S</b>		Off: 00:00

7. Quando finalizar a configuração, pressione o botão por 2 segundos para sair do setup.

# Instruções de funcionamento

Português

Maxspect Ltd. garante ao produto Sistema de Iluminação LED Maxspect™ Celestial a garantia de 12 meses relacionados com defeitos de fabricação, sendo contados a partir da data de compra. Se houver algum defeito no produto durante o período de garantia, a Maxspect realizará o reparo no equipamento (com peças novas) sem nenhum custo.

A garantia não se aplica ao produto que foi submetido a mau uso, manipulado por pessoas não autorizadas (técnicos ou não), usado de forma inadequada (instalação, local inadequado), alteração na configuração dos leds ou qualquer tipo de queda do produto que possa causar danos ao mesmo.

### **ISENÇÃO DE DANOS E CONSEQÜÊNCIAS:**

Você e qualquer outro usuário dos produtos Maxspect Ltd. não terá direito a quaisquer danos acidentais, incluindo, sem limitação, perda de uso da unidade, inconveniência, danos a bens pessoais, telefonemas, perda de renda ou lucros. Esta garantia lhe dá direitos legais específicos.

MAXSPECT LTD. NÃO FAZ NENHUMA GARANTIA OU REPRESENTAÇÃO, EXPRESSA OU IMPLÍCITA, COM RELAÇÃO À QUALIDADE DO PRODUTO, DESEMPENHO, COMERCIALIZAÇÃO OU ADEQUAÇÃO PARA UM DETERMINADO PROPÓSITO. COMO RESULTADO, ESTE PRODUTO, É VENDIDO "COMO ELE É", E VOCÊ O COMPRADOR ASSUME O RISCO TOTAL COM A SUA QUALIDADE E DESEMPENHO.

EM HIPÓTESE ALGUMA MAXSPECT LTD SÃO RESPONSÁVEIS DIRETOS, INDIRETOS, ESPECIAIS, INCIDENTAIS OU CONSEQÜENCIAIS DECORRENTES DE QUALQUER DEFEITO NO PRODUTO OU SUA DOCUMENTAÇÃO.

A garantia, aviso legal, e soluções estabelecidas acima são exclusivas. A substituir todos os outros, oral ou escrita, expressa ou implícita. Em nenhum momento, quaisquer negociantes Maxspect Ltd., agentes ou funcionários serão autorizados a fazer qualquer modificação, extensão ou acréscimo a esta garantia.

Alguns estados não permitem a exclusão ou limitação de garantias implícitas ou de responsabilidade por danos acidentais ou consequentes, portanto a limitação ou exclusão acima pode não se aplicar a você.

## Especificações

<b>Modulo Led</b>	<b>Dimensões (L x W x H)</b>	
	<b>Celestial C35-F, C35-S, C35-A</b>	140mm × 85mm x 65mm (5.5" x 3.3" x 2.5")
	<b>Celestial C70-F</b>	150mm × 100mm x 85mm (6" x 4" x 3.3")
	<b>Peso</b>	
	<b>Celestial C35-F, C35-S, C35-A</b>	250g (0.6 lb)
	<b>Celestial C70-F</b>	400g (0.9 lb)

---

<b>Fonte de Energia</b>	<b>Modelo</b>	GM50-240200-F (C35) GM601-240300 (C70)
	<b>Input Voltage / Current Output Voltage / Current</b>	1.5A/100-240vAC 50/60Hz 24vDC 2A (C35) 24vDC 3A (C70)
	<b>Peso</b>	250g /0.6 lb (C35) 250g /0.8 lb (C70)

### ATENÇÃO:

Para especificações mais recentes dos LEDs, tipos e espectro de cores, por favor, visite nosso website em [www.maxspect.com](http://www.maxspect.com)

As especificações estão sujeitas a alterações sem aviso prévio.

Peso e as dimensões são aproximados.



**亲爱的客户,**

感谢您选购我司商品。

为确保您的安全及使用本产品时得到最佳的效果，请仔细阅读此使用手册。

**用户资料:**

购买日期: \_\_\_\_\_

经销商名称: \_\_\_\_\_

经销商地址: \_\_\_\_\_

经销商网页: \_\_\_\_\_

经销商电邮: \_\_\_\_\_

经销商电话: \_\_\_\_\_

## 确认包装内容

请检查包装内物件是否齐全。

Celestial LED 灯体



电源



支架



请在操作前，仔细阅读本操作说明，并特别注意遵照下列安全建议。

请保留本说明书以便日後查阅。

### 安装及使用 Maxspect™ Celestial LED 灯具前，请注意：

1. 移除灯具外包装袋及灯具上的保护膜。
2. 开启灯具时请切勿用肉眼直视灯珠，否则可能会对眼睛造成伤害。

### 安全提示

1. **电源** — 禁止破坏两极插头或接地型插头的安全用途。两极插头有两个接触片，其中一个比较宽。接地型插头有两个接触片和一个接地插脚。两极插头的较宽接触片或接地型插头的接地插脚能够确保使用者的安全。如果提供的插头与您的插座不匹配，请联系电工更换插座。
2. **电源线保护** — 布置电源线时，确保电源线不被踩踏、挤压或阻挡。手湿时，切勿触碰插头或电源线。插入或拔出电源插头时，应始终紧握插头。
3. **安装** — 本设备只能安装于室内，并且使用由生产厂家提供及指定的附件，安装架与悬挂套件。

### 操作提示

1. 使用本设备时应始终遵照使用手册的操作说明。
2. 本设备的安装位置应远离热源，例如暖炉，也不能暴露于过度高温的环境，如阳光、火源之类。
3. 为降低火灾或雷击的危险，切勿把本设备暴露于淋雨、潮湿、滴水或溅水的环境中。
4. 本设备应安装或放置在不影响正常通风的位置上使用。
5. 本设备应远离产生强磁场的设备或装置。
6. 本设备只能使用干布清洁。

## 安装 Celestial LED 灯具

将灯具接通电源前，请使用所提供的支架将灯具安装妥当。

### 1. 支架的组装。

参照下图将灯体安装在支架上。



### 2. 将灯具安装于水族箱上。

组装好支架必须使用所提供的手拧螺丝将支架固定在适当的位置。如下图所示。



3. 调整灯具照射角度。



筒中

## 基本操作

### 注意

当灯具接通电源后，将自动运行对上一次灯具断电前的模式，包括所设置的时间，定义的程序，亮度值等。

电源接通后，将会显示 **Maxspect** 的商标及固件版本如下：

**MAXSPECT** c1.1

**Celestial** 灯具具有 2 种运作模式：手动模式(M)及自定义程序模式(A)。

在运作模式间切换：



1. 按下灯具上的旋钮不放超过 2 秒，灯具会在 3 种运作模式间进行切换。LCD 屏幕上会显示相应的模式状态：

手动模式：

<b>M</b>	A: 100%	B: 100%
	C: 100%	D: 100%

自定义程序模式：

<b>A</b>	12: 30
A: 100%	B: 100%

## 手动模式 “M”

在手动模式下，用户可以手动调整各组灯珠的亮度值。

此模式下，灯具将一直按照用户设置的亮度值点亮，直至用户改动设置。



1. 在手动模式“M”状态下，按一下旋钮，A组灯珠亮度值反白显示，此时旋转旋钮，可以调整亮度百分比数值。

<b>M</b>	A: <b>100%</b>	B: 100%
	C: 100%	D: 100%



2. 再按一下旋钮，切换到B组灯珠亮度值反白显示，此时旋转旋钮调整其亮度值。重复以上步骤，可设置C组及D组灯珠亮度值。

<b>M</b>	A: 60%	B: <b>100%</b>
	C: 100%	D: 100%

3. 设置完4组灯珠的亮度值后，再按一次旋钮，退出亮度设置状态。

4. 注意：C35-F/C70-F 型号灯具具有 A、B、C、D 4 组灯珠可供用户独立设置亮度，C35-S/C35-A 型号灯具具有 A、B 2 组灯珠可供独立设置（其“M”模式界面如下图）。

<b>M</b>	A: 100%
	B: 100%

## 自定义程序模式 “A”

在自定义程序模式“A”下，用户可以设置灯具各组灯组每天自动开启时间 **On Time**，自动关闭时间 **Off Time** 及最高亮度值 **Maximum Brightness**。

注意：设置好自定义程序后，当时钟运行到开灯时间点 **On Time**，灯具会自动用 30 分钟的时间由 0% 的亮度渐变到用户设定的最高亮度值 **Maximum Brightness**，而非直接由 0% 跳转到最高亮度值。当时钟运行到关灯时间点 **Off Time**，灯具同样会自动用 30 分钟时间由最高亮度值渐变到 0%。

例如，用户设置 A 组灯珠 8:00 开启，16:30 关闭，最高亮度为 80%。则 A 组灯珠会在 8:00-8:30 这半小时内由 0% 渐变到 80%，然后维持 80% 亮度，直至 16:30，然后在 16:30-17:00 这半小时内由 80% 亮度渐变到 0%。

用户设置 B 组灯珠 8:30 分开启，23:00 关闭，最高亮度 65%，则 B 组灯珠在 8:30-9:00 这半小时内由 0% 渐变到 65%，然后维持 65% 亮度，直至 23:00，然后在 23:00-23:30 这半小时内由 65% 亮度渐变到 0%。

	Maximum Brightness	On Time	Off Time
A 组	80%	08:00	16:30
B 组	65%	08:30	23:00

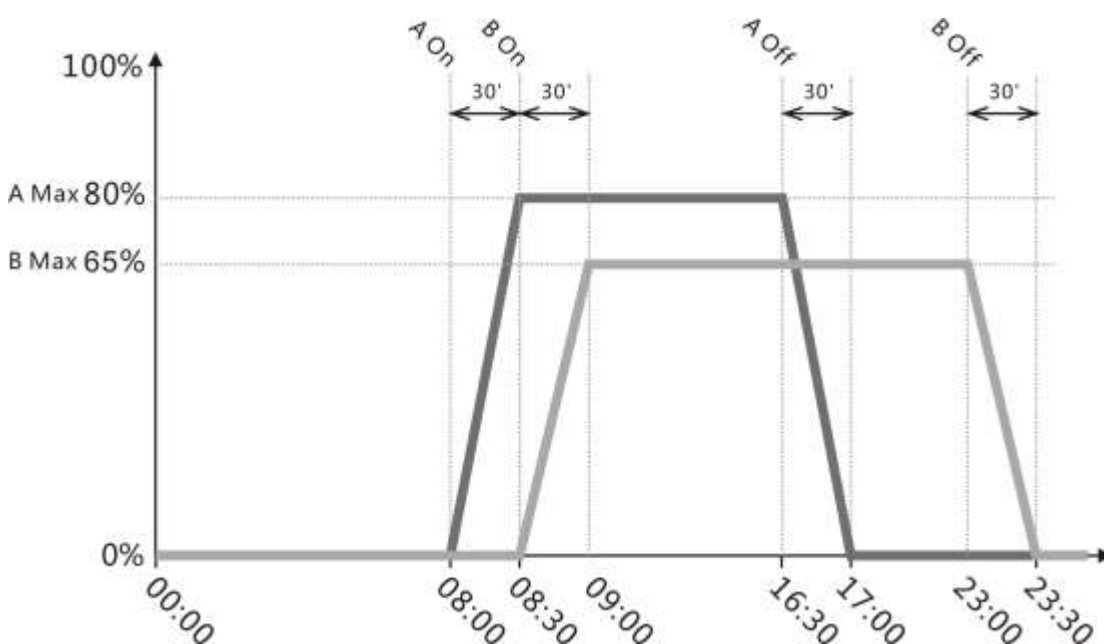



## 自定义程序模式 - 时钟设置



1. 在自定义程序模式“A”下，按一下旋钮，进入设置页面。首先时钟设置选项“Time”反白显示，此时再按一下旋钮，即可进入时钟设置界面。

A **TIME**  
S PROGRAM



2. 在时钟设置页面，首先是小时数值反白显示。此时旋转旋钮即可调整小时数值。

A TIME:  
S **06**: 30



3. 再按一下旋钮切换到分钟数值反白。旋转旋钮即可设置分钟数值。

A TIME:  
S 08: **30**

4. 时钟设置完成后，按下旋钮不放超过两秒，即可退出时钟设置页面。

## 自定义程序模式 - 程序设置



1. 在自定义程序模式“A”下，按一下旋钮，进入设置页面。首先时钟设置选项“Time”反白显示。

A	<b>TIME</b>
S	PROGRAM



2. 此时旋转旋钮，切换到程序设置选项反白显示，此时再按一下旋钮，即可进入程序设置页面。

A	TIME
<b>S</b>	<b>PROGRAM</b>

简中



3. 在程序设置页面中，首先是灯珠组字母“A”反白显示，此时旋转旋钮，可以在需要设置的灯珠组字母间循环切换（A → B → C → D → A）。

A	<b>A</b>	Max: 100%
<b>S</b>		On: 00:00



4. 选择好要设置的灯珠组后，按一下旋钮，切换至改组灯珠最高亮度值设置，“Max: \*\*%”反白显示，此时旋转旋钮，即可调整该组灯珠的最高亮度值。

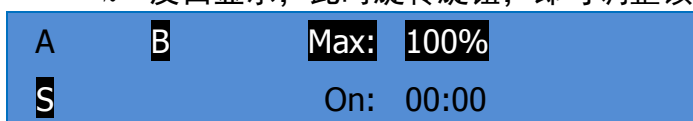

5. 设置好该组灯珠的最高亮度值后，再按一下旋钮，切换到该组灯组的开启时间值设置，“On: 00:00”反白显示，此时旋转旋钮即可调整该组灯珠开启时间，（每 30 分钟为单位）。

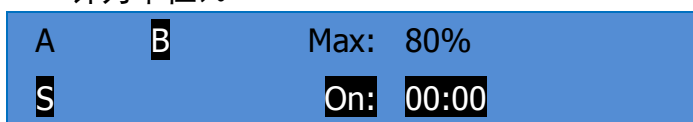

6. 设置好该组灯珠的开启时间后，再按一下旋钮，切换到该组灯组的关闭时间值设置，“Off: 00:00”反白显示，此时旋转旋钮即可调整该组灯珠关闭时间，（每 30 分钟为单位）。



7. 重复以上步骤设置好每一组灯珠的最高亮度值、开启时间及关闭时间后，按下旋钮不放超过 2 秒，即可退出程序设置页面。



所有迈光品牌（Maxspect）的 Celestial LED 照明系统产品自购买之日起 12 个月内若有质量问题，可享有 Maxspect 公司的保修服务。若在保修期内出现质量问题，Maxspect 公司将免费维修或更换配件。

若产品由于误用，被改装，发生事故，处理不当，或使用不当而受到损坏，或未经授权自行维修的，则不在保修范围之内。不在保修范围的情况包括但不限于，使用改装灯泡和修改电路等被视为误用或滥用而损坏产品的行为。

### **间接及附带损害免责声明：**

Maxspect 对您或其他使用者的间接或附带损害不承担责任。间接或附带损害包括但不限于，使用产品造成的损失或不便，对个人财产造成的损失，如电话，收入损失或盈利损失。本质保书赋予您合法权利，在不同的地区您还可能享有其它权利。

除上面明确提出的内容外，Maxspect 公司对产品的质量，性能，适销性或特别用途的适用性均没有作出明示或暗示的担保或陈述。因此，本产品“按现状”提供，您作为购买者承担有关此产品的质量和性能的全部风险。

在任何情况下，Maxspect 公司均不对因本产品或其文件的缺陷而引起的直接的、间接的、特别的、附带的或结果性的损害承担责任。

上述质保书，声明和故障排除方法是唯一版本，没有其它口头的或书面的，明示的或暗示的内容。在任何时候，Maxspect 公司的经销商，代理商或雇员都无权对此质保书进行更改、扩展或补充。

由于某些地区不允许此类附带性或结果性损害的免责或有限责任，上述限制可能不适用于您。

<b>LED 灯具</b>	<b>尺寸 (长 x 宽 x 高)</b>	
	<b>Celestial C35-F, C35-S, C35-A</b>	140mm × 85mm x 65mm (5.5" x 3.3" x 2.5")
	<b>Celestial C70-F</b>	150mm × 100mm x 85mm (6" x 4" x 3.3")
	<b>重量</b>	
	<b>Celestial C35-F, C35-S, C35-A</b>	250g (0.6 lb)
	<b>Celestial C70-F</b>	400g (0.9 lb)

---

<b>电源</b>	<b>型号</b>	GM50-240200-F (C35) GM601-240300 (C70)
	<b>输入电压 / 电流</b>	1.5A/100-240vAC 50/60Hz
	<b>输出电压 / 电流</b>	24vDC 2A (C35) 24vDC 3A (C70)
	<b>重量</b>	250g /0.6 lb (C35) 250g /0.8 lb (C70)

**提示:**

更多详细信息, 请浏览我们的官方网站:

[www.maxspect.com](http://www.maxspect.com)

规格如有变更, 恕不另行通知。

重量和尺寸均为约数。

**親愛的客戶,**

多謝您選購我們公司的商品。

為確保您的安全及使用本產品時得到最佳的效果，請詳細閱讀此使用說明書。

**用戶資料:**

購買日期:

\_\_\_\_\_

經銷商名稱:

\_\_\_\_\_

經銷商地址:

\_\_\_\_\_

\_\_\_\_\_

經銷商網頁:

\_\_\_\_\_

經銷商電郵:

\_\_\_\_\_

經銷商電話:

\_\_\_\_\_

## 確認包裝內容

請檢查包裝內物件是否齊全。

Celestial LED 燈體



電源



支架





請在操作前，仔細閱讀本操作說明，並特別注意遵照下列安全建議。

請保留本說明書以便日後查閱。

### 安裝及使用 **Maxspect™ Celestial LED** 燈具前，請注意：

1. 移除燈具外包裝袋及燈具上的保護膜。
2. 開啟燈具時請切勿用肉眼直視燈珠，否則可能會對眼睛造成傷害。

### 安全提示

1. **電源** — 禁止破壞兩極插頭或接地型插頭的安全用途。兩極插頭有兩個接觸片，其中一個比較寬。接地型插頭有兩個接觸片和一個接地插腳。兩極插頭的較寬接觸片或接地型插頭的接地插腳能夠確保使用者的安全。如果提供的插頭與您的插座不匹配，請聯系電工更換插座。
2. **電源線保護** — 布置電源線時，確保電源線不被踩踏、擠壓或阻擋。手濕時，切勿觸碰插頭或電源線。插入或拔出電源插頭時，應始終緊握插頭。
3. **安裝** — 本設備只能安裝於室內，並且使用由生產廠家提供及指定的附件，安裝架與懸掛套件。

### 操作提示

1. 使用本設備時應始終遵照使用手冊的操作說明。
2. 本設備的安裝位置應遠離熱源，例如暖爐，也不能暴露於過度高溫的環境，如陽光、火源之類。
3. 為降低火災或雷擊的危險，切勿把本設備暴露於淋雨、潮濕、滴水或濺水的環境中。
4. 本設備應安裝或放置在不影響正常通風的位置上使用。
5. 本設備應遠離產生強磁場的設備或裝置。
6. 本設備只能使用乾布清潔。

## 安裝 Celestial LED 燈具

將燈具接通電源前，請使用所提供的支架將燈具安裝妥當。

### 1. 支架的組裝。

參照下圖將燈體安裝在支架上。



### 2. 將燈具安裝於水缸上。

組裝好支架必須使用所提供的手擰螺絲將支架固定在適當的位置。如下圖所示。



3. 調整燈具照射角度。



## 基本操作

### 注意

當燈具接通電源後，將自動運行對上一次燈具斷電前的模式，包括所設置的時間，定義的程序，亮度值等。

電源接通後，將會顯示 **Maxspect** 的商標及軟件版本如下：

**MAXSPECT** c1.1

**Celestial** 燈具有 2 種運作模式：手動模式(M)及用家自定程序模式(A)。

在運作模式間切換：



1. 按下燈具上的旋鈕不放超過 2 秒，燈具會在 3 種運作模式間進行切換。LCD 屏幕上會顯示相應的模式狀態：

手動模式：

<b>M</b>	A: 100%	B: 100%
	C: 100%	D: 100%

用家自定程序模式：

<b>A</b>	12: 30
A: 100%	B: 100%

## 手動模式 “M”

在手動模式下，用戶可以手動調整各組燈珠的亮度值。

此模式下，燈具將一直按照用戶設置的亮度值點亮，直至用戶改動設置。



1. 在手動模式“M”狀態下，按一下旋鈕，A 組燈珠亮度值反白顯示，此時旋轉旋鈕，可以調整亮度百分比數值。

<b>M</b>	A: <b>100%</b>	B: 100%
	C: 100%	D: 100%



2. 再按一下旋鈕，切換到 B 組燈珠亮度值反白顯示，此時旋轉旋鈕調整其亮度值。重復以上步驟，可設置 C 組及 D 組燈珠亮度值。

<b>M</b>	A: 60%	B: <b>100%</b>
	C: 100%	D: 100%

3. 設置完 4 組燈珠的亮度值後，再按一次旋鈕，退出亮度設置狀態。

4. 注意：C35-F/C70-F 型號燈具有 A、B、C、D 4 組燈珠可供用戶獨立設置亮度，C35-S/C35-A 型號燈具有 A、B 2 組燈珠可供獨立設置（其“M”模式界面如下圖）。

<b>M</b>	A: 100%
	B: 100%

## 用家自定程序模式 “A”

在用家自定程序模式“A”下，用戶可以設置燈具各組燈組每天自動開啟時間 **On Time**，自動關閉時間 **Off Time** 及最高亮度值 **Maximum Brightness**。

注意：設置好用家自定程序後，當時鐘運行到開燈時間點 **On Time**，燈具會自動用 30 分鐘的時間由 0% 的亮度漸變到用戶設定的最高亮度值 **Maximum Brightness**，而非直接由 0% 跳轉到最高亮度值。當時鐘運行到關燈時間點 **Off Time**，燈具同樣會自動用 30 分鐘時間由最高亮度值漸變到 0%。

例如，用戶設置 A 組燈珠 8:00 開啟，16:30 關閉，最高亮度為 80%。則 A 組燈珠會在 8:00–8:30 這半小時內由 0% 漸變到 80%，然後維持 80% 亮度，直至 16:30，然後在 16:30–17:00 這半小時內由 80% 亮度漸變到 0%。

用戶設置 B 組燈珠 8:30 分開啟，23:00 關閉，最高亮度 65%，則 B 組燈珠在 8:30–9:00 這半小時內由 0% 漸變到 65%，然後維持 65% 亮度，直至 23:00，然後在 23:00–23:30 這半小時內由 65% 亮度漸變到 0%。

	Maximum Brightness	On Time	Off Time
A 組	80%	08:00	16:30
B 組	65%	08:30	23:00

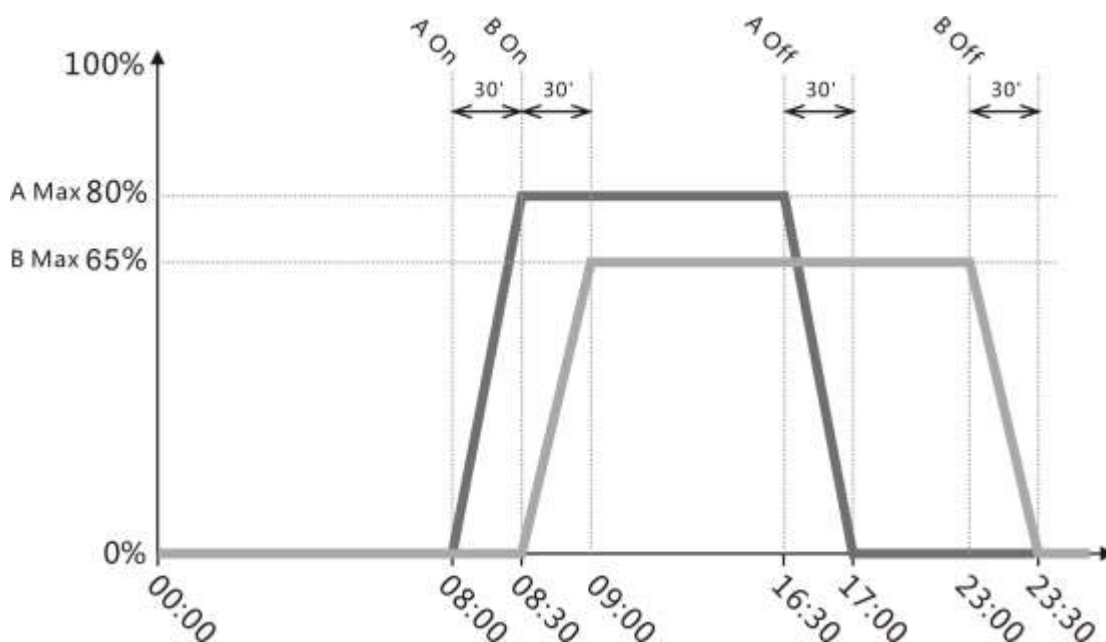

## 用家自定程序模式 - 時鐘設置



1. 在用家自定程序模式“A”下，按一下旋鈕，進入設置頁面。首先時鐘設置選項“Time”反白顯示，此時再按一下旋鈕，即可進入時鐘設置界面。

A TIME  
S PROGRAM



2. 在時鐘設置頁面，首先是小時數值反白顯示。此時旋轉旋鈕即可調整小時數值。

A TIME:  
S 06: 30



3. 再按一下旋鈕切換到分鐘數值反白。旋轉旋鈕即可設置分鐘數值。

A TIME:  
S 08: 30

4. 時鐘設置完成後，按下旋鈕不放超過兩秒，即可退出時鐘設置頁面。

## 用家自定程序模式 - 程序設置



1. 在用家自定程序模式“A”下，按一下旋鈕，進入設置頁面。首先時鐘設置選項“Time”反白顯示。

A	<b>TIME</b>
S	PROGRAM



2. 此時旋轉旋鈕，切換到程序設置選項反白顯示，此時再按一下旋鈕，即可進入程序設置頁面。

A	TIME
S	<b>PROGRAM</b>



3. 在程序設置頁面中，首先是燈珠組字母“A”反白顯示，此時旋轉旋鈕，可以在需要設置的燈珠組字母間循環切換（A → B → C → D → A）。

A	<b>A</b>	Max: 100%
S		On: 00:00





4. 選擇好要設置的燈珠組後，按一下旋鈕，切換至改組燈珠最高亮度值設置，“Max: \*\*%” 反白顯示，此時旋轉旋鈕，即可調整該組燈珠的最高亮度值。

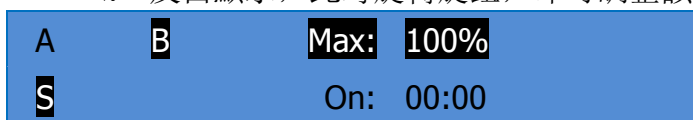

5. 設置好該組燈珠的最高亮度值後，再按一下旋鈕，切換到該組燈組的開啟時間值設置，“On: 00:00” 反白顯示，此時旋轉旋鈕即可調整該組燈珠開啟時間，（每 30 分鐘為單位）。

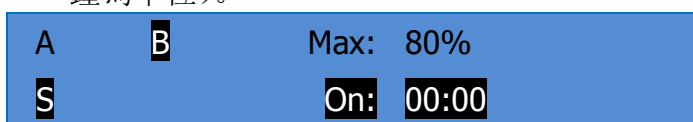

6. 設置好該組燈珠的開啟時間後，再按一下旋鈕，切換到該組燈組的關閉時間值設置，“Off: 00:00” 反白顯示，此時旋轉旋鈕即可調整該組燈珠關閉時間，（每 30 分鐘為單位）。



7. 重復以上步驟設置好每一組燈珠的最高亮度值、開啟時間及關閉時間後，按下旋鈕不放超過 2 秒，即可退出程序設置頁面。



所有邁光品牌（Maxspect）的 Celestial LED 照明系統產品自購買之日起 12 個月內若有質量問題，可享有 Maxspect 公司的保修服務。若在保修其內出現質量問題，Maxspect 公司將免費維修或更換配件。

若產品由於誤用，被改裝，發生事故，處理不當，或使用不當而受到損壞，或未經授權自行維修的，則不在保修範圍之內。不在保修範圍的情況包括但不限於，使用改裝燈泡和修改電路等被視為誤用或濫用而損壞產品的行為。

### 間接及附帶損害免費聲明：

Maxspect 對您或其他使用者的間接或附帶損害不承擔責任。間接或附帶損害包括但不限於，使用產品造成的損失或不便，對個人財產造成的損失，如電話，收入損失或盈利損失。本質保書賦予您合法權利，在不同的地區您還可能享有其它權利。

除上面明確提出的內容外，Maxspect 公司對產品的質量，性能，適銷性或特別用途的適用性均沒有作出明示或暗示的擔保或陳述。因此，本產品“按現狀”提供，您作為購買者承擔有關此產品的質量和性能的全部風險。

在任何情況下，Maxspect 公司均不對因本產品或其文件的缺陷而引起的直接的、間接的、特別的、附帶的或結果性的損害承擔責任。

上述質保書，聲明和故障排除方法是唯一版本，沒有其它口頭的或書面的，明示的或暗示的內容。在任何時候，Maxspect 公司的經銷商，代理商或雇員都無權對此質保書進行更改、擴展或補充。

由於某些地區不允許此類附帶性或結果性損害的免責或有限責任，上述限制可能不適用於您。

<b>LED 燈具</b>	<b>尺寸 (長 x 寬 x 高)</b>	
	<b>Celestial C35-F, C35-S, C35-A</b>	140mm × 85mm x 65mm (5.5" x 3.3" x 2.5")
	<b>Celestial C70-F</b>	150mm × 100mm x 85mm (6" x 4" x 3.3")
	<b>重量</b>	
	<b>Celestial C35-F, C35-S, C35-A</b>	250g (0.6 lb)
	<b>Celestial C70-F</b>	400g (0.9 lb)

---

<b>電源</b>	<b>型號</b>	GM50-240200-F (C35) GM601-240300 (C70)
	<b>輸入電壓 / 電流</b>	1.5A/100-240vAC 50/60Hz
	<b>輸出電壓 / 電流</b>	24vDC 2A (C35) 24vDC 3A (C70)
	<b>重量</b>	250g /0.6 lb (C35) 250g /0.8 lb (C70)

**提示:**

更多詳細信息，請瀏覽我們的官方網站：

[www.maxspect.com](http://www.maxspect.com)

規格如有變更，恕不另行通知。

重量和尺寸均為約數。

## ***Szanowny Kliencie,***

Dziękujemy i gratulujemy za zakup naszego produktu.

Prosimy o uważne przeczytanie poniższych instrukcji w celu uzyskania optymalnej wydajności i bezpieczeństwa.

### **User Memo:**

Data zakupu: \_\_\_\_\_

Sprzedawca: \_\_\_\_\_

Adres sprzedawcy: \_\_\_\_\_

Strona web  
sprzedawcy: \_\_\_\_\_

E-mail sprzedawcy: \_\_\_\_\_

Telefon sprzedawcy: \_\_\_\_\_

### **Odwiedz nas na Facebook i Twitter!**



<https://www.facebook.com/Maxspect>



<http://twitter.com/maxspectled>

**Polski**

## Zawartosc opakowania

Proszę, sprawdź zawartość opakowania:

**Modul LED Celestial**



**Zasilacz**



**Stojak**



## Warunki bezpieczeństwa

Proszę o uważne przeczytanie poniższych instrukcji obsługi przed użyciem zestawu oświetleniowego LED Maxspect™ Celestial. Proszę zwrócić szczególną uwagę na zawarte poniżej instrukcje.

Prosimy o przechowanie podręcznika do wykorzystania w przyszłości.

### Przed użyciem ledowego systemu oświetleniowego Maxspect™

1. Usunąć wszelkie opakowania / ofoliowanie, które chronią lampę i inne części zestawu.
2. Nie spoglądać nigdy bezpośrednio na diody LED po włączeniu systemu oświetleniowego. Niepoprawne używanie aparatu zwiększa ryzyko uszkodzenia wzroku.

### Bezpieczeństwo

1. Zasilanie – nie anulować uziemienia wtyczki. Jeśli wtyczka nie pasuje do gniazdka, prosimy o skontaktowanie się z elektrykiem w celu wymiany gniazdka na odpowiednie.
2. Przewody zasilające powinny być prowadzone sposobem uniemożliwiającym chodzenie po nich bądź przygniatanie przedmiotami umieszczonymi w ich pobliżu bądź nad nimi. Nigdy nie chwytac wtyczki i kabla zasilającego mokrą ręką; nie ciągnąć kabla a chwytac za wtyczkę w celu jej odłączenia lub podłączenia.
3. Oświetlenie nadaje się tylko do użytku wewnątrz lokali, nie instalować na zewnątrz; do instalacji używać wyłącznie elementów przewidzianych i dostarczonych przez producenta.

### Użytkowanie

1. Użytkowanie – podczas użytkowania ledowego systemu oświetleniowego Celestial stosować się zawsze do instrukcji obsługi zawartych w poniższym podręczniku
2. Temperatura – urządzenie powinno być umieszczone z dala od źródeł ciepła, takich jak kaloryfery; nie wystawiać na nadmierne działanie promieni słonecznych, ognia itp.
3. Wilgoc – aby zmniejszyć ryzyko pożaru oraz porażenia prądem nie narażać urządzenia na działanie deszczu, wilgoci, kapiącej wody bądź chłapania wodą.
4. Wentylacja – urządzenie powinno być umieszczone w miejscu gwarantującym swobodny przepływ powietrza.
5. Pole magnetyczne – aparat powinien być umieszczony z dala od sprzętu i urządzeń generujących silne pole magnetyczne.
6. Czyszczenie – czyścić często używając wyłącznie suchej miękkiej szmatki. Przed czyszczeniem odłączyć z sieci zasilania.

Polski

## Montaż ledowego systemu oświetleniowego Celestial

Przed podłączeniem oświetlenia Celestial do sieci elektrycznej przeprowadzić całkowity montaż struktury przy użyciu stojaka.

### 1. Assemble the Stand.

Zamontować stojak poprzez włożenie szyn przewodniczących znajdujących się po obu stronach modułu Celestial, tak jak przedstawiono na ilustracji:



### 2. Zabezpieczenie stojaka.

Po umiejscowieniu szyn w przewodnicach rozsunąć stojak na pożądaną rozpiętość; dokręcić śruby blokujące w celu zabezpieczenia stojaka.





## 3. Ustaw ką.



## Obsługa podstawowa

Prosimy postępować wg poniższych instrukcji w celu włączenia i oprogramowania modułu Celestial.

### Uwaga

**Moduł Celestial włącza się automatycznie po podłączeniu do sieci zasilania i wyłącza po odcięciu od prądu.**

W przypadku odcięcia modułu od prądu i ponownego podłączenia do zasilania wprowadzone wcześniej ustawienia przywracane są automatycznie.

**Po podłączeniu do sieci elektrycznej na wyświetlaczu LCD pojawi się logo Maxspect oraz wersja firmware.**

MAXSPECT c1.1

## Programowanie e i Automatyczne



1. Aby wybrać tryb nacisnąć pokrętło kontrolne i trzymać je naciśnięte przez 2 sekundy. Monitor LCD wyświetli odpowiednio "M" bądź "A".

### Tryb ręczny:

<b>M</b>	A: 100%	B: 100%
	C: 100%	D: 100%

### Tryb automatyczny:

<b>A</b>	12: 30
A: 100%	B: 100%

## Tryb ręczny "M"

W trybie ręcznym użytkownik może regulować, przy pomocy pokrętła kontrolnego, jasność obu kanałów.



1. Nacisnąć 1 raz pokrętło kontrolne aby wejść do ustawień. Zostanie wybrany kanał A jako pierwszy. Kręcić pokrętłem kontrolnym w celu uregulowania jasności światła.

<b>M</b>	A: <b>100%</b>	B: 100%
	C: 100%	D: 100%



2. Nacisnąć pokrętło kontrolne ponownie aby przejść do ustawień kanału B. Kręcić pokrętłem kontrolnym w celu uregulowania jasności światła. Powtórzyć tę samą sekwencję dla wszystkich kanałów.

<b>M</b>	A: 60%	B: <b>100%</b>
	C: 100%	D: 100%

3. Nacisnąć pokrętło kontrolne ponownie aby wyjść z ustawień.
4. Uwaga: modele C35-F/C70-F mają 4 kanały, natomiast modele C35-S/C35-A mają 2 kanały; interfejs na wyświetlaczu LCD będzie wyglądać nieco inaczej

<b>M</b>	A: 100%
	B: 100%

## Tryb automatyczny "A"

W trybie automatycznym użytkownik może personalizować profil fotoperiodu na każdym z kanałów za pomocą ustawień **On Time**, **Off Time** i **Maximum Brightness** (maksymalna jasność).

Kanał będzie się włączał automatycznie wg ustawień **On Time**, jasność ruszy od 0% będzie powoli wzrastać aby w przeciągu 30 minut osiągnąć maksymalną jasność (**Maximum Brightness**) zaprogramowaną dla danego kanału. Ustawiona maksymalna jasność zacznie progresywnie się zmniejszać począwszy od godziny ustawionej jako **Off Time**, kanał wyłączy się automatycznie po upływie 30 minut.

Na przykład, na poniższym diagramie przedstawiono jak zaprogramować jasność światła tak, aby kanał A włączał się o godz. 8:00, osiągał maksymalną jasność (zaprogramowaną jako 80%) o 8:30 utrzymywał ją do godz. 16:30 i wyłączał się o godz. 17:00 czyli po 30-minutowym okresie zmniejszania się jasności. Podobnie kanał B włącza się o godz. 8:30, osiąga zaprogramowaną 60% jasność o 9:00, utrzymuje ją do 23:00 po czym wyłącza się o godz. 23:30.

	Maximum Brightness	On Time	Off Time
<b>Kanał A</b>	80%	08:00	16:30
<b>Kanał B</b>	65%	08:30	23:00

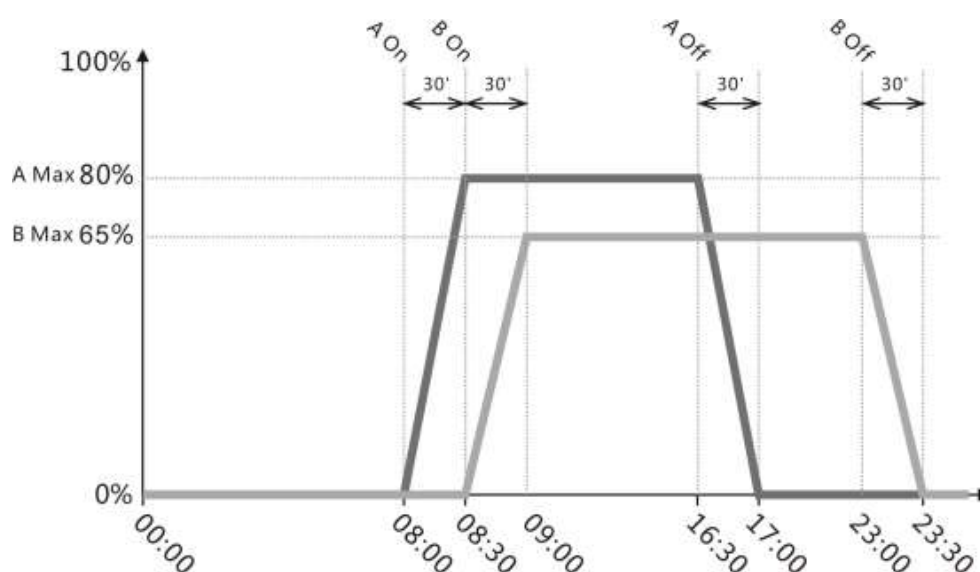

## Tryb automatyczny – Ustawienie zegara



1. Nacisnąć 1 raz pokrętko kontrolne aby wejść do ustawień.

A **TIME**  
S PROGRAM



2. Po wejściu do menu zegara wyświetla się czas ustawiony fabrycznie. Kręcić pokrętkiem kontrolnym, aby ustawić godzinę (np. 06:30 → 08:30)

A TIME:  
S **08:** 30



3. Przycisnąć pokrętko kontrolne, aby przejść do ustawiania minut. Kręcić pokrętkiem kontrolnym, aby ustawić minuty.

A TIME:  
S 08: **30**

4. Po ustawieniu zegara nacisnąć pokrętko kontrolne i przytrzymać przez 2 sekundy, aby przejść ponownie do menu programowania.

## Tryb automatyczny – programowanie fotoperiodu



1. Nacisnąć 1 raz pokrętko kontrolne aby wejść do ustawień.

A	<b>TIME</b>
S	PROGRAM



2. Kręcić pokrętkiem kontrolnym aby wybrać pomiędzy ustawieniami, które zamierzamy zmodyfikować. (np. Time → Program)

A	TIME
S	<b>PROGRAM</b>



3. Przycisnąć pokrętko kontrolne ponownie aby wybrać ustawienie. Wybrać kanał A jako pierwszy. Kręcić pokrętkiem kontrolnym aby przejść do innego kanału. (np. A → B)

A	<b>A</b>	Max: 100%
S		On: 00:00

## Instrukcje obsługi



4. Przycisnąć pokrętkę kontrolną aby przejść do ustawiania jasności. Krecić pokrętką kontrolną aby wybrać zadany stopień jasności. (np. 100% → 80%)

A	B	Max:	100%
S		On:	00:00



5. Przycisnąć pokrętkę kontrolną aby przejść do ustawiania godziny startu **On Time**. Krecić pokrętką kontrolną aby wybrać godzinę **On Time**, godzina rośnie w odstępach 30 minutowych (np. 00:00 → 08:30)

A	B	Max:	80%
S		On:	00:00



6. Przycisnąć pokrętkę kontrolną aby przejść do ustawiania godziny końca **Off Time**. Krecić pokrętką kontrolną aby wybrać godzinę **Off Time**, godzina rośnie w odstępach 30 minutowych (np. 00:00 → 22:30)

A	B	Max:	80%
S		Off:	00:00

7. Po zakończeniu programowania przycisnąć i przytrzymać pokrętkę kontrolną przez 2 sekundy aby wyjść z ustawień.

Polski





Ledowe systemy oświetleniowe Maxspect™ Celestial pokryte są 12 miesięczną gwarancją , która obejmuje wady produkcji.

Jeżeli wada produkcji pojawi się w okresie gwarancji, Maxspect Ltd. zastrzega sobie prawo naprawy (przy użyciu zarówno części nowych jak i regenerowanych) bądź wymiany (na produkt nowy bądź regenerowany) produktu wadliwego, bez dodatkowych kosztów.

Gwarancja nie obejmuje urządzeń uszkodzonych na skutek niewłaściwego użytkowania, modyfikacji, upadków, nie autoryzowanych prób naprawy.

### **WYŁĄCZENIE ZA SZKODY WTÓRNE I PRZYPADKOWE:**

Użytkownik urządzeń Maxspect nie ma prawa roszczyć żądań odszkodowania za szkody pośrednie i bezpośrednie, bez jakichkolwiek ograniczeń, wynikające z: osobistych niedogodności, uszkodzenia mienia osobistego, urządzeń telefonicznych, strat materialnych, itp. Niniejsza gwarancja obejmuje określone prawa konsumenta.

MAXSPECT LTD. NIE GWARANTUJE, A JEDNOCZESNIE NIE DEKLARUJE, POŚREDNIO I BEZPOSREDNIO, W ODNIESIENIU DO JAKOŚCI PRODUKTÓW: WYDAJNOŚCI PRODUKTU, PRZYDATNOŚCI DO CELÓW INNYCH NIŻ WSKAZANY. W REZULTACIE PRODUKT TEN, SPRZEDAWANY W OBECNEJ POSTACI, PODDANY JEST CAŁKOWITEMU RYZYKU NABYWCY ZWIĄZANEMU Z JEGO JAKOŚCIĄ I WYDAJNOŚCIĄ.

W ŻADNYM WYPADKU MAXSPECT LTD. NIE MOŻE ZOSTAĆ POCIĄGNIĘTY DO ODPOWIEDZIALNOŚCI ZA SZKODY POŚREDNIE I BEZPOŚREDNIE, SPECYFICZNE I WYPADKOWE, WYNIKAJĄCE Z JAKIEGOKOLWIEK PROBLEMU ZWIĄZANEGO Z PRODUKTEM BĄDŹ JEGO DOKUMENTACJĄ.

Gwarancja oraz wyżej wymienione zasady zastępują wszelkie inne, wyrażone ustnie i pisemnie, wyraźnie bądź w sposób domniemany. W żadnym wypadku sprzedawca, agent, pracownik, itp. nie jest uprawniony do naniesienia jakichkolwiek poprawek, modyfikacji, poszerzeń i dodatków do niniejszej gwarancji.

Nie wszystkie kraje przewidują wyłączenie bądź ograniczenie odpowiedzialności za szkody wypadkowe i wtórne, w związku z czym niniejsze zasady gwarancji mogą nie mieć zastosowania w Państwach wypadku.

## Specyfikacja

<b>Modul LED</b>	<b>Wymiary (L x W x H)</b>	
	<b>Celestial C35-F, C35-S, C35-A</b>	140mm × 85mm x 65mm (5.5" x 3.3" x 2.5")
	<b>Celestial C70-F</b>	150mm × 100mm x 85mm (6" x 4" x 3.3")
	<b>Waga</b>	
	<b>Celestial C35-F, C35-S, C35-A</b>	250g (0.6 lb)
	<b>Celestial C70-F</b>	400g (0.9 lb)

---

<b>Zasilacz</b>	<b>Model</b>	GM50-240200-F (C35) GM601-240300 (C70)
	<b>Voltaggio ingresso / Corrente</b>	1.5A/100-240vAC 50/60Hz
	<b>Voltaggio uscita / Corrente</b>	24vDC 2A (C35) 24vDC 3A (C70)
	<b>Peso</b>	250g /0.6 lb (C35)
		250g /0.8 lb (C70)

### Uwaga:

Prosimy odwiedzać stronę [www.maxspect.com](http://www.maxspect.com) w celu zapoznania się z ewentualnymi aktualizacjami konfiguracji dido Led, kolorów widma, itp

Dane techniczne mogą ulec zmianie bez uprzedzenia.

Waga i wymiary są przybliżone





**Maxspect Company Limited**

[www.maxspect.com](http://www.maxspect.com)

NOTE: Products, packaging, features and specifications are subject to change.

All screen images are simulated.

© 2009-2014 Maxspect Limited. Reproduction in whole or in part without written permission is prohibited. All rights reserved. Maxspect and Celestial are trademarks of Maxspect Limited. Cree and XLamp are trademarks of Cree, Inc.

Celestial Owner's Manual Version 1.0